

## LAYHER SYSTEM SOLUTIONS FOR CIVIL ENGINEERING AND BRIDGE CONSTRUCTION

Edition 01.2021  
Ref. No. 8116.208

Quality management  
certified as per  
DIN EN ISO 9001

Typical applications,  
solutions and useful ideas  
for Layher scaffolding systems  
in civil engineering and  
bridge construction.



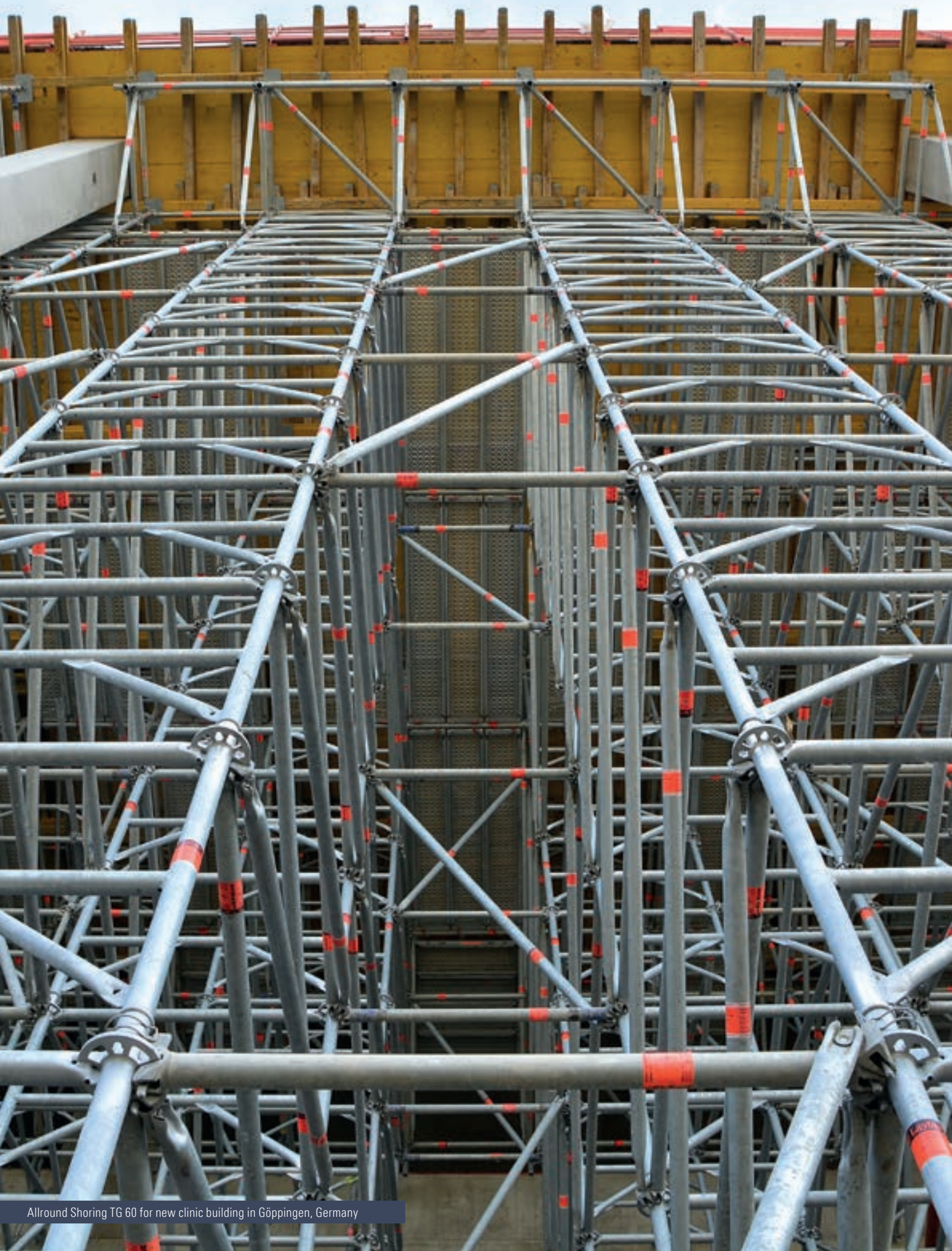

Allround Shoring TG 60 for new clinic building in Göppingen, Germany

# 1. CONTENTS

<b>1. Layher – The Company</b> .....	<b>4</b>	5.1.6. Temporary bridges / bridging small spans.....	27
1.1. Continual product innovations and design improvements.....	4	5.1.7. Temporary bridges / bridging medium spans.....	28
1.2. Products for greater safety when working.....	5	5.1.8. Temporary bridges / bridging large spans.....	29
1.3. Large stocks and rapid material availability.....	5	5.2. Reinforcing, concreting and work scaffolding.....	32
1.4. Close-knit network of service centres.....	5	5.2.1. Reinforcing and concreting scaffolding.....	32
1.5. Digital planning with LayPLAN SUITE.....	6	5.2.2. Work scaffolding.....	33
1.6. Expert assemblers and technical assistance at the construction site.....	6	5.2.3. Concreting scaffolding with cavity wall brackets.....	35
1.7. Strong partnership right from the start.....	7	5.2.4. Work scaffolding, free-standing and suspended for complex geometries ..	36
1.8. Technical seminars for regular training of employees.....	7	5.2.5. Tunnel scaffolding for reinforcing work and further treatment.....	40
<b>2. Layher solutions at every site</b> .....	<b>8</b>	5.3. Shoring.....	42
2.1. Civil engineering and industrial construction.....	8	5.3.1. Allround Shoring TG 60.....	42
2.2. Civil engineering, below ground.....	9	5.3.2. Combination of Allround Scaffolding and Shoring TG 60.....	52
2.3. Bridge construction.....	10	5.3.3. Allround heavy-duty column.....	54
<b>3. Digital scaffolding planning with Layher SIM*</b> .....	<b>12</b>	5.3.4. Allround Heavy-Duty Tower XL.....	55
3.1. Your access to BIM.....	12	5.4. Site protection.....	56
3.2. The modules of LayPLAN SUITE.....	13	5.4.1. Protect System.....	57
3.2.1. LayPLAN CLASSIC for SpeedyScaf and Allround Scaffolding.....	13	5.4.2. Scaffolding tarpaulins and nets.....	59
3.2.2. LayPLAN MATERIAL MANAGER for LayPLAN CLASSIC / LayPLAN CAD ..	13	5.4.3. Weather protection roofs.....	59
3.2.3. LayPLAN CAD for planning in 3D.....	14	5.5. Site equipment.....	62
3.2.4. LayPLAN VR VIEWER.....	14	5.5.1. Cable and pipeline bridges.....	62
3.2.5. LayPLAN TO RSTAB.....	15	5.5.2. Advertising signs.....	63
3.3. From processing model data to using it in 3D in SIM.....	15	5.6. Accessories and logistics.....	64
<b>4. Safer working with Layher</b> .....	<b>16</b>	5.6.1. Flat roof guardrail.....	64
4.1. Layher SpeedyScaf® – The Economical System.....	16	5.6.2. Balustrade clamp.....	64
4.1.1. Advance Guardrail.....	17	5.6.3. Logistics / material flow / storage.....	64
4.1.2. Speedy I-Guardrail.....	17	<b>6. Safety and documentation</b> .....	<b>66</b>
4.2. Layher Allround Scaffolding® – One system. Many solutions.....	18	6.1. Layher quality management.....	66
4.2.1. Advance Guardrail.....	19	6.2. Internal and external monitoring.....	67
4.2.2. Allround Guardrail System (ARGS).....	19	6.3. Approvals.....	67
4.2.3. Allround Modular Stairtower.....	19	6.4. Welding technology.....	68
4.3. Layher Allround Shoring TG 60 – The Flexible System.....	20	6.5. Trial and test stand.....	68
4.3.1. Assembly of shoring towers.....	21	6.6. Technical documentation.....	69
4.3.2. Integrated deck levels for safer access to slab formwork.....	21	6.7. Catalogues and price lists.....	69
4.3.3. Integration of bracket-mounted walkways.....	21	<b>7. Sustainability</b> .....	<b>70</b>
4.4. Layher protective systems.....	22	7.1. Product sustainability.....	71
4.4.1. Protect System – Well protected.....	22	7.2. Sustainability through initiatives.....	71
4.4.2. Keder Roof XL – Lightweight and strong.....	23	7.3. Process sustainability.....	71
4.4.3. Cassette roof – Sturdy and strong.....	23	<b>8. Success stories</b> .....	<b>73</b>
<b>5. Products and solutions</b> .....	<b>24</b>	8.1. New multi-storey car park, Heilbronn, Germany.....	74
5.1. Site accesses.....	24	8.2. New office building, Berlin, Germany.....	75
5.1.1. Allround Platform stairtower.....	24	8.3. New residential and office buildings, Heilbronn, Germany.....	76
5.1.2. Allround Modular stairtower.....	25	8.4. Various projects, Bamberg, Germany.....	77
5.1.3. Compact stairtower.....	26		
5.1.4. Site stairtower 200.....	26		
5.1.5. Stairtower 500 and 750.....	27		

# 1. LAYHER – THE COMPANY



Layher's main plant in Gueglingen-Eibensbach

The Layher name has been synonymous with high-quality scaffolding systems, outstanding service and dependable partnership for more than seven decades now. Even today, development, production, logistics and management are still all in one place, where the conditions are best for achieving "Quality Made By Layher": in Gueglingen-Eibensbach. At two locations, over an area of 318,000 m<sup>2</sup>, we produce our pioneering system scaffolding using highly automated methods. Our deep roots in the region, and a culture of service and innovation we've lived by for generations, form the basis for our promise to customers all over the world: "More possibilities!"

## 1.1. CONTINUAL PRODUCT INNOVATIONS AND DESIGN IMPROVEMENTS

As leading innovators, we work continually to make scaffolding construction even simpler, even faster and above all even safer with our products. The development work focuses on:

- ▶ Improving safety during assembly and dismantling.
- ▶ Increasing assembly capacity thanks to lower weight, more ergonomic shape and reduced number of components.
- ▶ Increasing efficiency and profitability.
- ▶ Complete integrability of new products into existing system.
- ▶ Opening up of new fields of business with new products.

The Layher Lightweight philosophy embodies this innovative spirit: the use of high-tensile steels and design improvements in lightweight products allow for assembly capacity to be increased by up to 10% and transport costs to be reduced by up to 12%.



Continual product innovations and design improvements

## 1.2. PRODUCTS FOR GREATER SAFETY WHEN WORKING

Safety when working is in everyone’s interest. When you use Layher products, you satisfy the statutory requirements relating to safety when working, in every respect and in their latest version, or you even set new standards for safety at the site. This includes facade scaffolding with advancing side protection, shoring and staintowers that can be assembled safely on the ground and then moved by crane, or shoring towers that are assembled directly at the place of use with system-integrated and advancing side protection.

Learn more in Section 4.



System-integrated advancing side protection during assembly of shoring towers TG 60

## 1.3. LARGE STOCKS AND RAPID MATERIAL AVAILABILITY

Layher can draw on flexible production resources and significant inventories, and so can guarantee customers uniquely fast delivery at all times. We can deliver dependably and punctually for orders placed worldwide. “No time to lose” is also the motto of our logistics concept: customers can collect the materials they need from their Layher service centre, have them sent to their warehouse, or delivered just-in-time to the site. This means they can start work without delay and complete their projects efficiently while maintaining the top quality Layher has come to represent. To cope with peak demand, we have an extensive rental stock of TG 60 material available.



Shipping warehouse at the main plant

## 1.4. CLOSE-KNIT NETWORK OF SERVICE CENTRES

A worldwide network of subsidiary companies ensures that we are always close to our customers. You can rely on our Layher standards wherever you are in the world: local warehouses, technical support, training in accordance with national regulations and safety standards. The benefits for you: We can respond optimally to market-specific needs, because we know the local conditions, cultural characteristics and of course each country’s specific regulations. This makes us competent partners, for internationally operating companies too.

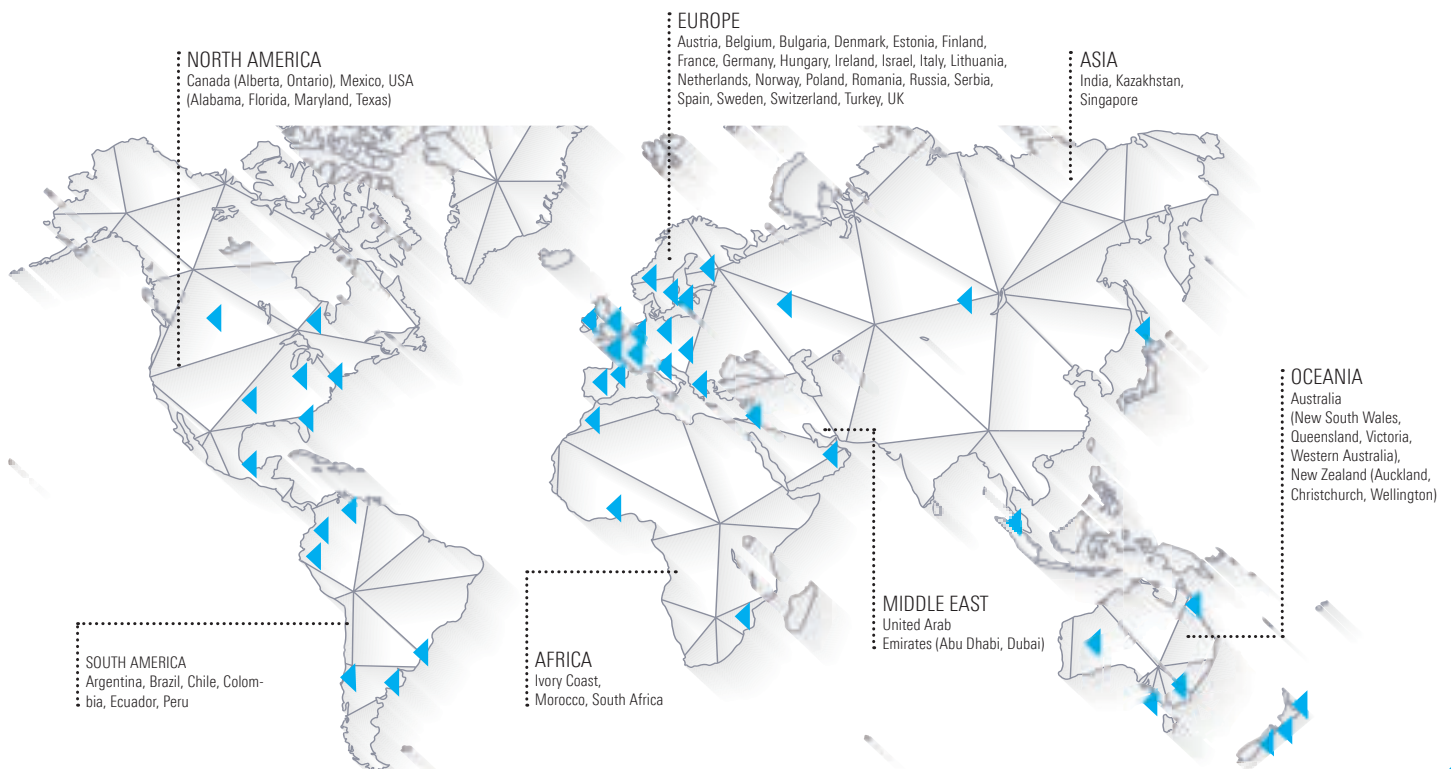

## 1.5. DIGITAL PLANNING WITH LAYPLAN SUITE

Scaffolding Information Modeling – SIM for short – is an intelligent process based on 3D models. SIM not only allows scaffolding constructors to plan, assemble and manage temporary scaffolding structures more efficiently, but also affords access to BIM at the same time. With the integrated Layher software solution LayPLAN SUITE, customers are provided with a powerful tool for the SIM process.



LayPLAN SUITE – efficiency and transparency from planning right through to implementation

## 1.6. EXPERT ASSEMBLERS AND TECHNICAL ASSISTANCE AT THE CONSTRUCTION SITE

Our priority is our customers' success. This is why we believe in close cooperation, and invest in genuine and lasting partnerships at every level.

Our well-qualified engineers devote themselves to your specific requirements, finding solutions for you that deliver the right results at the right price – including directly on the site. It may be that new applications have to be tried out or that assistance is needed when assembling Layher scaffolding for the first time. Expert assemblers are there to assist you and your employees – at your site too.



Technical advice from expert assemblers on the spot

### 1.7 STRONG PARTNERSHIP RIGHT FROM THE START

At Layher we're convinced that close and trusting cooperation between manufacturer, scaffolding company and end customer is the right model to ensure success when working on construction sites and projects. Only with this strategic partnership can jointly defined objectives be achieved economically and safely. Because it's not enough to have an outstanding product for successful scaffolding construction – what's crucial is what you do with it.

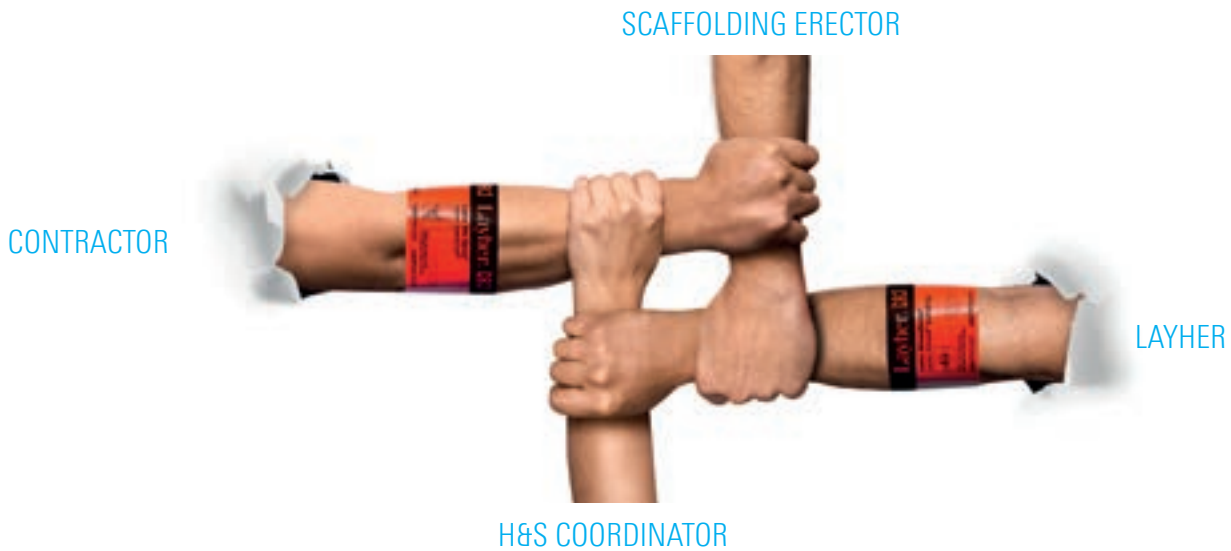

### 1.8. TECHNICAL SEMINARS FOR REGULAR TRAINING OF EMPLOYEES

In toughly contested markets, companies need qualified employees. That's why Layher organises regular technical seminars specifically for scaffolding construction and building companies, preparing you for current and future challenges in scaffolding, and giving you more confidence and knowhow to make the most of Layher products.

We supplement our seminars with many further offerings, such as practical product training and open days for construction companies, with interesting presentations by industry specialists and intense group discussions amongst scaffolding professionals to encourage the exchange of ideas.



Extensive technical documentation for all products



Technical seminars on theory and practice

## 2. LAYHER SOLUTIONS AT EVERY SITE



### 2.1. CIVIL ENGINEERING AND INDUSTRIAL CONSTRUCTION



Large bakery/logistics centre in Schafisheim, Switzerland



Office building in Oehringen, Germany



Industrial plant construction in Brake, Germany



High-bay warehouse in Nufringen, Germany





2.2. CIVIL ENGINEERING, BELOW GROUND



Tunnel construction in Erfurt, Germany

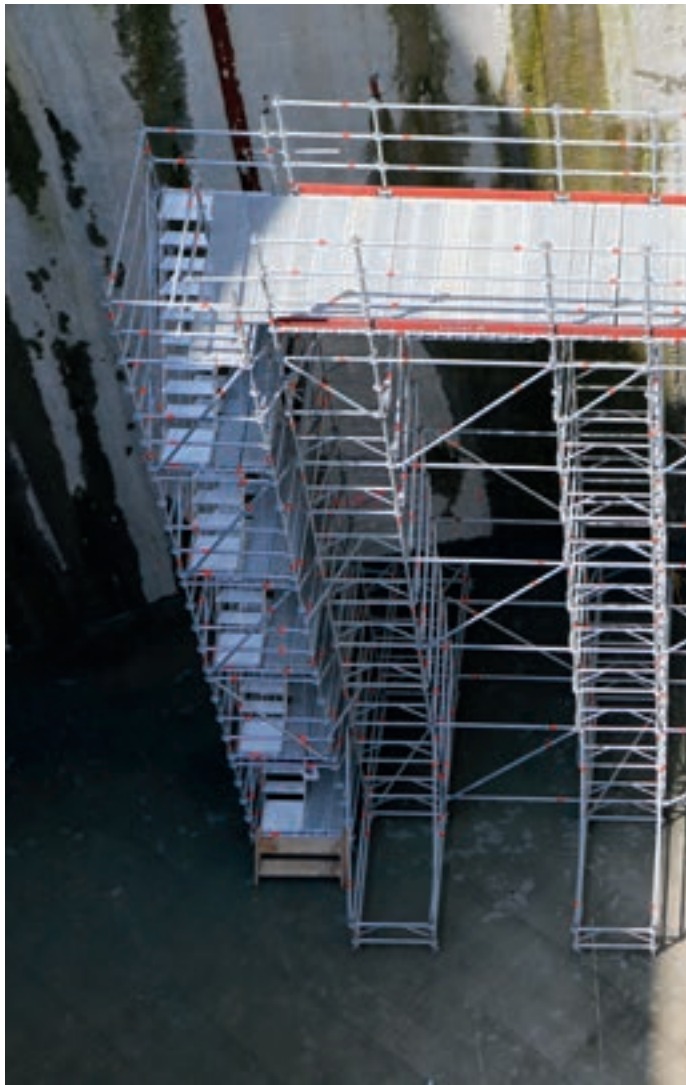

Sewer laying in Bottrop, Germany



Light rail station in Sydney, Australia



Pumped storage power station in Limmern, Switzerland



2.3. BRIDGE CONSTRUCTION



Building of new bridge in Schraudenbach, Germany



Pylon repair in Speyer, Germany



Building of new bridge in Pforzheim, Germany



Building of new bridge in Schierstein, Germany



Building of new bridge in Stuttgart, Germany



Building of new bridge in Stuttgart, Germany



Building of new bridge in Bad Wuennenberg, Germany



Repair of bridge in Fribourg, Switzerland



Repair of bridge in Sydney, Australia

# 3. DIGITAL SCAFFOLDING PLANNING WITH LAYHER SIM®

## 3.1. YOUR ACCESS TO BIM

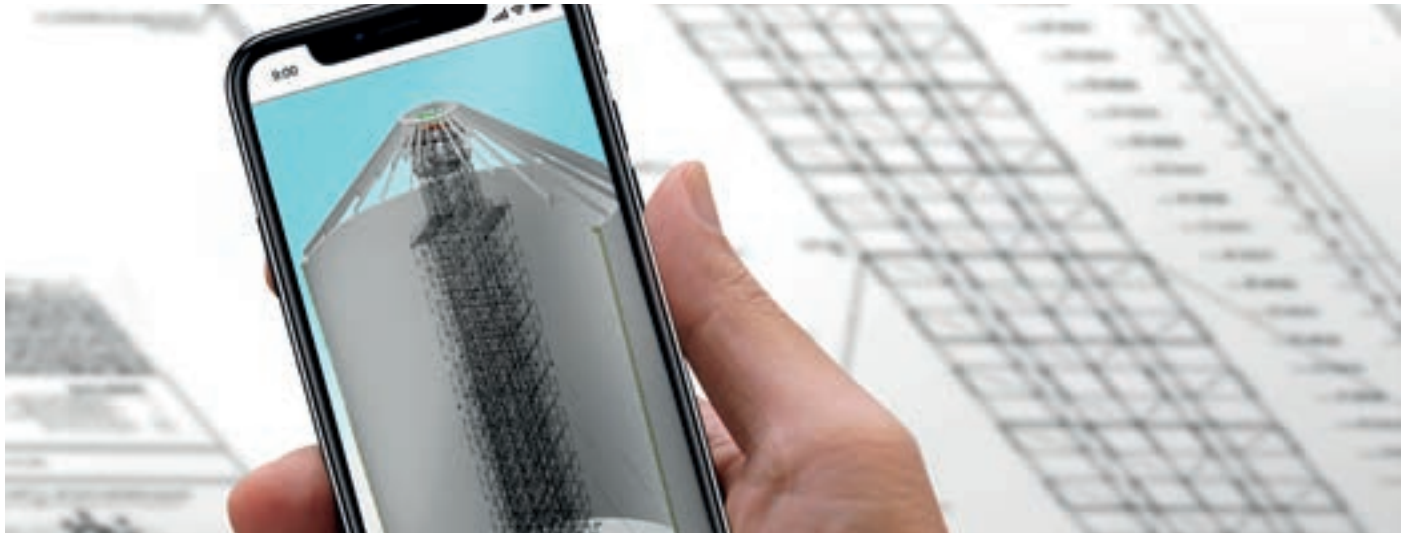

LayPLAN SUITE – efficiency and transparency from planning right through to implementation

Digitalisation is affecting every industry. That includes scaffolding construction. And rightly so, because nothing else optimises project planning so effectively, while opening up for you enormous potential for both transparency and cost savings. Layher therefore asked itself the question of how the BIM concept – Building Information Modeling – originating in civil engineering could be adapted to scaffolding as temporary structures. Because the proven Layher systems permit faster and safer upward access, yet are not part of the actual structure. Furthermore, scaffolding can also be used independently of civil engineering projects, for example as stand-alone structures like temporary bridges. The result is SIM: Scaffolding Information Modeling.

Scaffolding Information Modeling – SIM for short – is a process based on 3D models and designed by Layher to meet the specific requirements of scaffolding construction. SIM not only allows you to plan, assemble and manage temporary scaffolding structures more efficiently, but also affords access to BIM at the same time. With the integrated Layher software solution LayPLAN SUITE, you have a powerful tool for the SIM process: LayPLAN CLASSIC facilitates a start in digital planning by allowing automated planning of predefined scaffolding applications – and if required even with temporary roof structures. For complex scaffolding structures as part of large-scale engineering scaffolding, there is LayPLAN CAD. Detailed information on the modules of LayPLAN SUITE can be found on the following pages.

Dependable 3D planning of scaffolding structures without collisions is just one of many benefits. Added to that are the realistic visualisation of scaffolding, allowing for coordination of work with other trades or simulation of the construction sequence; transfer of the scaffolding planning to structural analysis programs; and output of material lists and assembly plans. Transparency at every step results in a reduction in costs and an increase in safety and profitability. When they work with Layher's scaffolding construction cus-

tomers, both building contractors and end customers in industry benefit from the many advantages SIM has to offer: a high degree of planning certainty, cost control and, above all, the ability to complete projects on schedule thanks to efficient and undisrupted construction processes. Delays and added costs due to inadequate planning are a thing of the past.

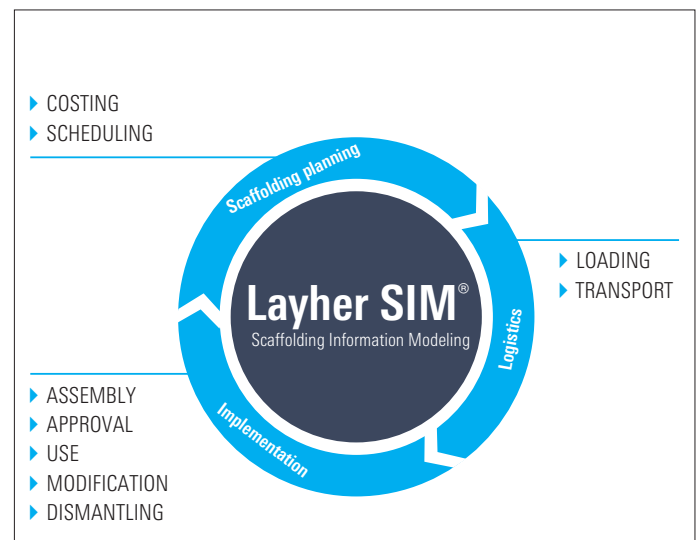

### THE BENEFITS FOR YOU AT A GLANCE

- ▶ Transparency in all work steps and cost control.
- ▶ Increase in safety and profitability for every project.
- ▶ Planning and scheduling certainty at every site.
- ▶ Your access to BIM.

## 3.2. THE MODULES OF LAYPLAN SUITE

### 3.2.1. LayPLAN CLASSIC for SpeedyScaf and Allround Scaffolding

LayPLAN CLASSIC facilitates a start in digital planning by allowing automated planning of predefined scaffolding applications: whether they're for circular or facade scaffolding made from SpeedyScaf, for birdcage scaffolding and free-standing towers made from Allround Scaffolding, or for structures with temporary roofs.

Once the key data has been entered, scaffolding erectors receive in seconds a scaffolding proposal that includes anchoring, bracing and side protection. During the design phase, the overall length, standing heights and areas are continuously calculated and displayed to reflect the latest plan. A materials list can also be easily created at the push of a button. Scaffolding erectors benefit from more certainty when planning the commercial and technical details; from optimised use of their stocks; and from full cost transparency at every stage of the project.

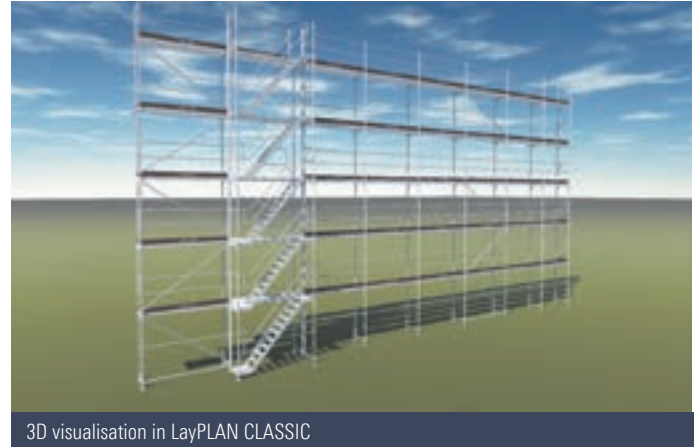

3D visualisation in LayPLAN CLASSIC



Facade scaffolding with brick guard level and vehicle access using LayPLAN CLASSIC SpeedyScaf



Planning of a weather protection roof with Keder Roof XL on Allround support scaffolding using LayPLAN CLASSIC

#### The functions of LayPLAN CLASSIC

- ▶ Automated planning of standardised scaffolding structures using SpeedyScaf, Allround Scaffolding and Layher weather protection roofs.
- ▶ Export function to LayPLAN CAD.
- ▶ Automatic 2D drawings.
- ▶ 3D visualisation for order acquisition.
- ▶ Real-time material list – for transport and assembly.

### 3.2.2. LayPLAN MATERIAL MANAGER for LayPLAN CLASSIC and LayPLAN CAD

The LayPLAN MATERIAL MANAGER allows material lists to be created and edited – for example splitting into different construction sections to permit prices and weights to be considered separately.

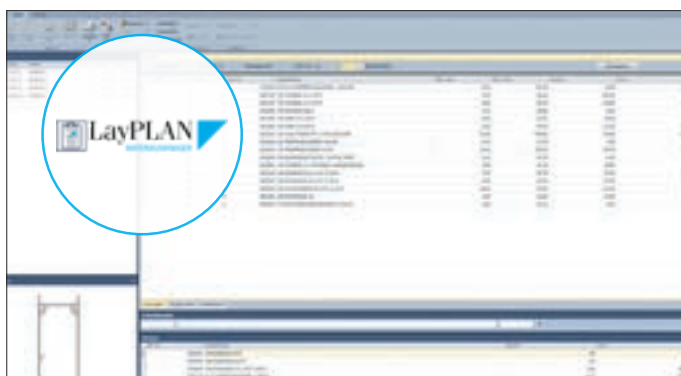

#### The functions of LayPLAN MATERIAL MANAGER

- ▶ Automatic creation of material lists from LayPLAN CLASSIC and LayPLAN CAD.
- ▶ Manual editing of material lists, for example splitting them into construction sections and applications.
- ▶ Detailed information on the scaffolding components including preview image
- ▶ Output as PDF and export in Excel.
- ▶ Optional component images on the material lists in the printout – this makes it easier to identify components during loading and assembly.

## 3. Digital scaffolding planning with Layher SIM®

### 3.2.3. LayPLAN CAD for planning in 3D

When it comes to complex scaffolding structures as part of large-scale engineering scaffolding, look no further than LayPLAN CAD. This is a plug-in for Autodesk AutoCAD. It permits 3-dimensional planning of scaffolding structures of all types.

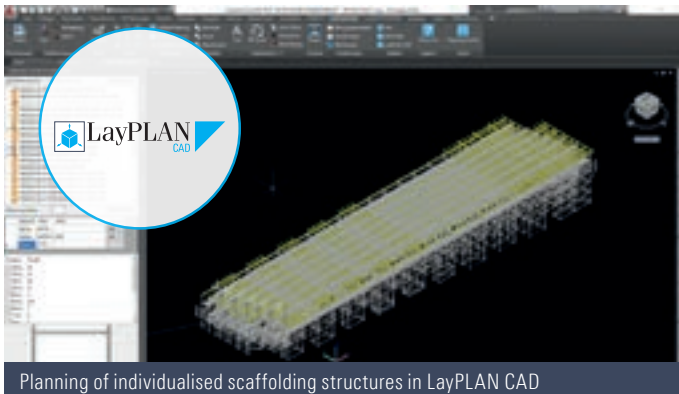

Planning of individualised scaffolding structures in LayPLAN CAD

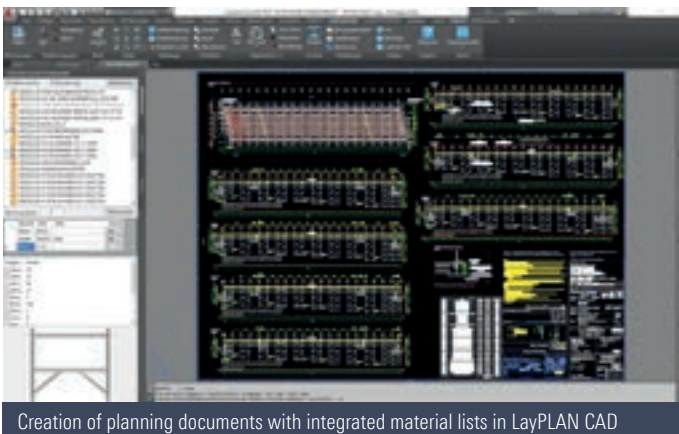

Creation of planning documents with integrated material lists in LayPLAN CAD

### 3.2.4. LayPLAN VR VIEWER

The free-of-charge LayPLAN VR VIEWER enables virtual tours of scaffolding structures, to convey a realistic spatial impression of the overall situation. Based on the data from LayPLAN CAD, Layher can create VR models for display in the LayPLAN VR VIEWER for you. We'd be happy to assist you on the spot with our specialists and equipment for your VR presentation.

#### The functions of LayPLAN VR VIEWER

- ▶ Virtual tours of scaffolding structures with VR headset (e.g. Oculus Rift).
- ▶ Optional display of VR models in Desktop mode.
- ▶ Integrated measurement and comment function.
- ▶ Conveying of a realistic spatial impression of the overall situation, for order acquisition and for coordination with other trades or for construction sequence simulation.

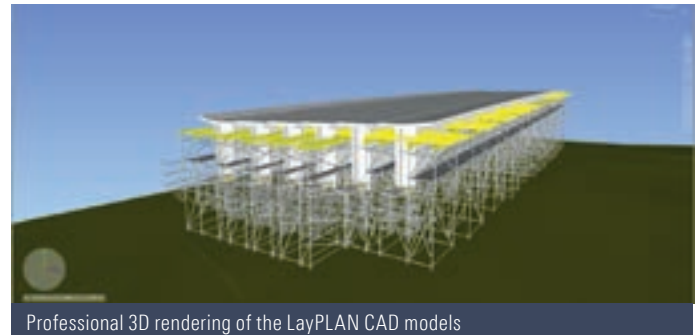

Professional 3D rendering of the LayPLAN CAD models

#### The functions of LayPLAN CAD

- ▶ Scaffolding planning and design in 3D.
- ▶ Basic planning can be done in an automated process using the proven LayPLAN CLASSIC – saving a great deal of time.
- ▶ Dependable visual collision check thanks to realistic rendering as a volume model.
- ▶ Extensive component library with a convenient search function – including prefabricated assemblies and template drawings for even faster design.
- ▶ Preview image of components and output as 3D model.
- ▶ Automatic component labelling.
- ▶ Real-time material list for transport and assembly – the required material is guaranteed to be there where it's needed.
- ▶ Further editing of the model data in visualisation software (e.g. rendering, VR) for order acquisition and for coordination with other trades or for construction sequence simulation.
- ▶ Further editing of the model data in RSTAB for structural strength calculations as part of project-related verifications of stability. Unlike in remodelling which is otherwise necessary, this avoids error sources and saves time when planning.
- ▶ Available in German, English, French and Spanish.

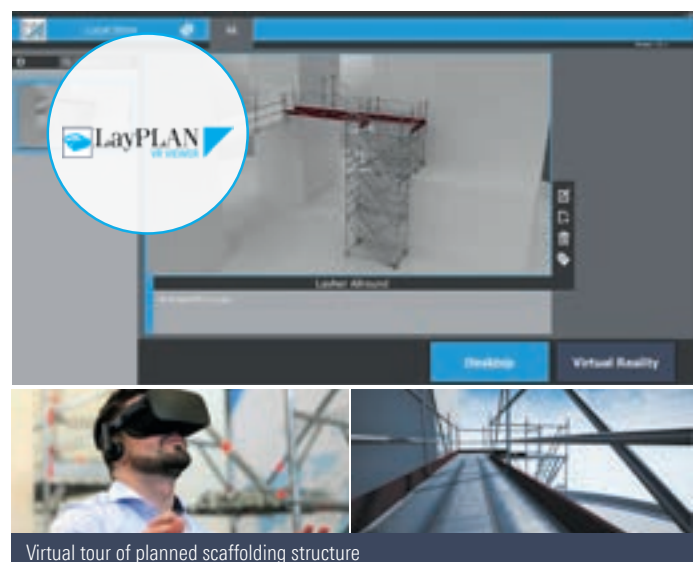

Virtual tour of planned scaffolding structure

#### 3.2.5. LayPLAN TO RSTAB

For structural strength verification of scaffolding structures, frame analysis programs are generally used. Using the LayPLAN TO RSTAB module, all modeling-relevant information about an Allround Scaffolding structure can be imported three-dimensionally into the RSTAB frame analysis program from Dlubal. Automated transmission of the information means that re-entering the model data is not needed. This means that the user will benefit from an enormous time saving, and also avoid a possible source of errors during modelling.



Transmission of model data with the aid of LayPLAN TO RSTAB

#### The functions of LayPLAN TO RSTAB

- ▶ Time saving thanks to automated 3D model transfer of Allround Scaffolding structures.
- ▶ Transmission of all structurally relevant information according to the approvals (geometry, cross-sections, materials, frame types, eccentricities and non-linear connections).
- ▶ Avoidance of possible sources of errors during modelling in the frame analysis program.

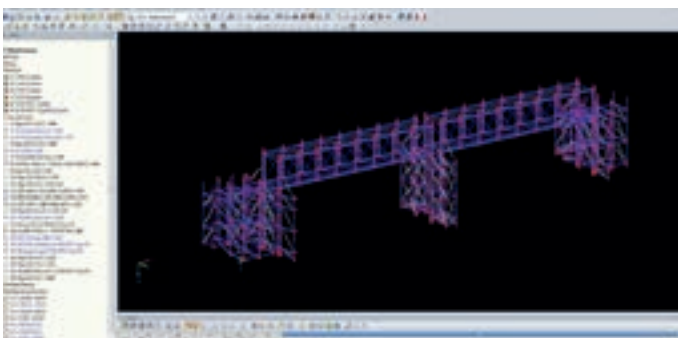

Imported RSTAB model, prepared for structural strength computations

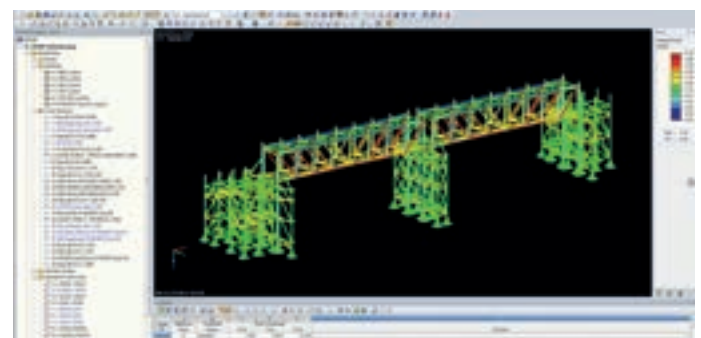

Structural strength computations based on definition of nodal supports and loads

### 3.3. FROM PROCESSING MODEL DATA TO USING IT IN 3D IN SIM

Digital 3D scaffolding planning affords many advantages over planning in 2D as previously used: from a high degree of detail in planning and in drawings to the visual collision check and to professional visualisation of the scaffolding structure. The basis for scaffolding planning is 3D building model data. As a rule, this is available from your customer as part of the BIM process. Alternatively, it is possible to model the 3D building model data on

the basis of 2D plans or manual building measurements or 3D scans, or to use it directly by means of a plug-in. Contact your Layher contact partner about the 3D scan service. Once 3D scaffolding planning with LayPLAN CAD is finished, the data can also be used without any problem for downstream processes, for example for the creation of part lists or construction sequence simulation.

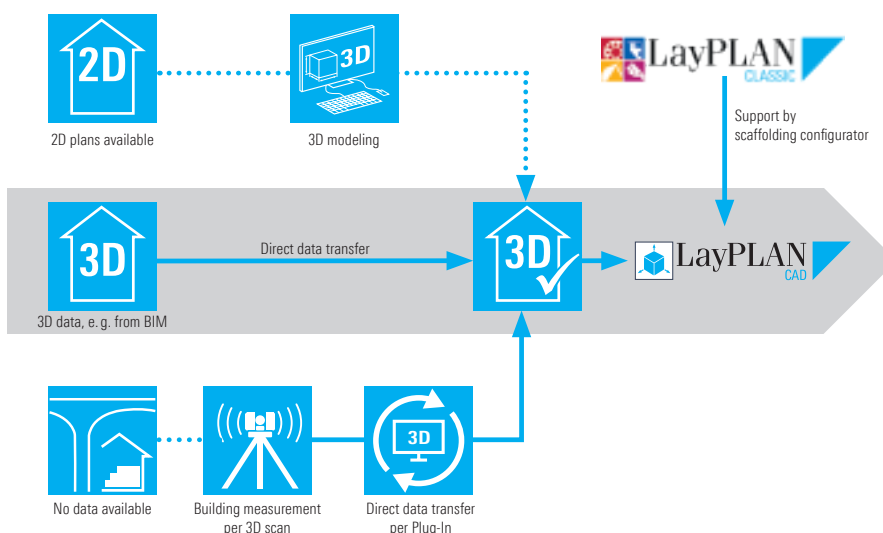

- ▶ Realistic 3D scaffolding planning.
- ▶ Visualisation of the design for professional presentation.
- ▶ Collision check.
- ▶ Data transfer to structural analysis programs.
- ▶ Material lists for logistic planning and costing.
- ▶ 2D plans for assembly.
- ▶ Construction sequence simulation.
- ▶ VR model for virtual tour.
- ▶ Communication / data exchange with mobile devices.

# 4. SAFER WORKING WITH LAYHER

## 4.1. LAYHER SPEEDYSCAF® – THE ECONOMICAL SYSTEM



SpeedyScaf is a frame scaffolding system using only 6 basic components. With a few lightweight components, bolt-free connection technology and a logical and safe assembly sequence, it enables you to quickly create a secure base for every job and every trade. Easier, safer and more ergonomic to use for a wide range of applications, SpeedyScaf can be employed equally profitably for both scaffolding construction and for building trades. A large number of matching expansion parts enables you to come up with solutions for widely differing tasks.

- ▶ Efficiency in transport, handling and assembly thanks to the weight-reduced Layher Lightweight products.
- ▶ Advancing side protection with system-integrated I-Guardrail and Advance Guardrail.
- ▶ Easy planning and job preparation.
- ▶ Matching system components.

### Type-tested and with building authority approval

- ▶ SpeedyScaf, 0.73 m wide, made of hot-dip-galvanised steel: **Z-8.1-16.2**
- ▶ SpeedyScaf, 1.09 m wide, made of hot-dip-galvanised steel: **Z-8.1-840**
- ▶ SpeedyScaf, 0.73 m wide, made of aluminium: **Z-8.1-844**
- ▶ SpeedyScaf, 0.73 m wide, made of hot-dip-galvanised steel: Type test **TP-16-007** for 7 assembly variants with platform heights of up to 100 metres.

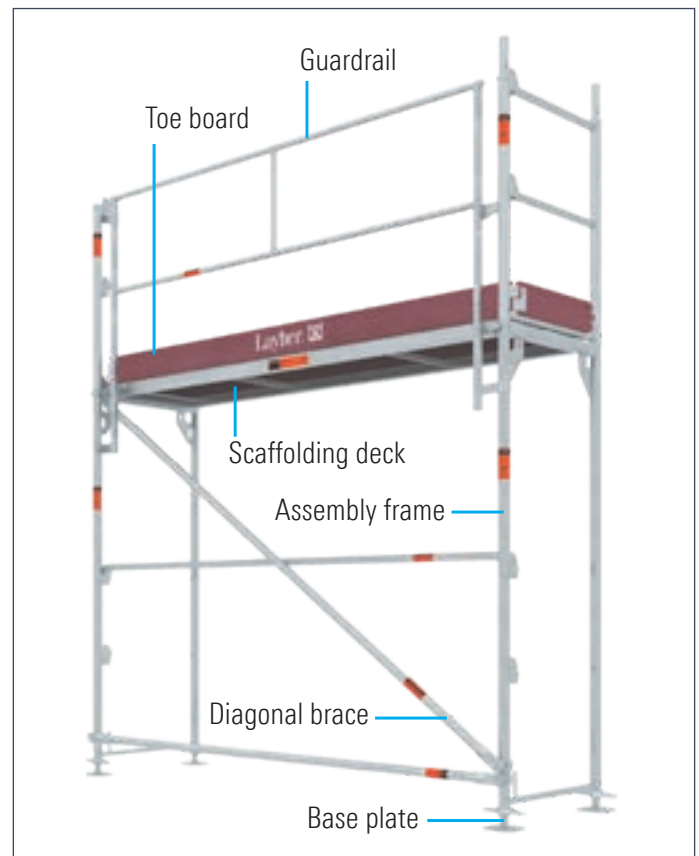



### 4.1.1. Advance Guardrail

With the Advance Guardrail, you can continue to make use of your entire scaffolding stock.

- ▶ Lightweight and complete system made of aluminium – usable with both SpeedyScaf and Allround Scaffolding.
- ▶ Maximum flexibility for assembling, modifying and dismantling, as it is usable even after a scaffolding level has been completed.
- ▶ Consisting of two aluminium Advance Guardrail posts and one aluminium telescoping Advance Guardrail (longitudinal side of scaffolding).
- ▶ Assembled from the secured level directly underneath, without fixed assembly or dismantling direction.
- ▶ The one-piece Advance End Guardrail for the end face of the scaffolding is quickly clamped between the guardrail of the secured level and the deck ledger of the unsecured level using the spring mechanism.
- ▶ Matches every scaffolding tube with dia. 48.3 mm.



### 4.1.2. Speedy I-Guardrail

The Speedy I-Guardrail acts as an advancing fall protection system during assembly and dismantling of SpeedyScaf, and remains inside the scaffolding over its entire service life. All scaffolding components, apart from the guardrails, in your scaffolding stocks are re-used.

- ▶ Permits fitting of an advancing two-piece side protection in one assembly step.
- ▶ System consisting of handrail and intermediate rail, fittable from a secured level.
- ▶ Assembly possible in both directions – enabling assembly by several work teams at once.
- ▶ Low weight yet high stability and long life.
- ▶ Thanks to a special logistic solution based on Layher tube pallets, the one-piece I-Guardrail can be transported and stored in a space-saving manner.

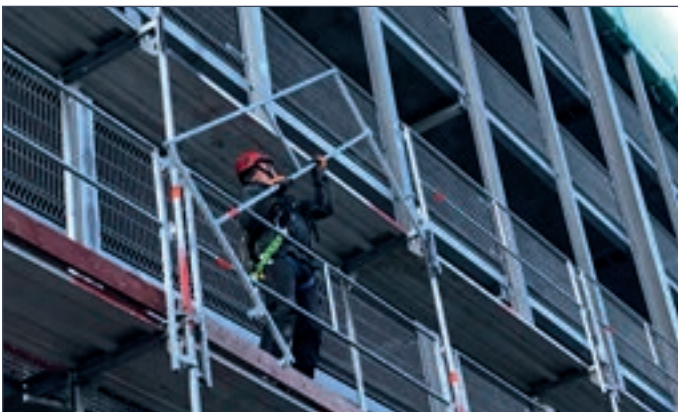

SpeedyScaf assembly with I-Guardrail



Facade work scaffolding with I-Guardrails

## 4. Safer working with Layher

### 4.2. LAYHER ALLROUND SCAFFOLDING® – ONE SYSTEM. MANY SOLUTIONS.

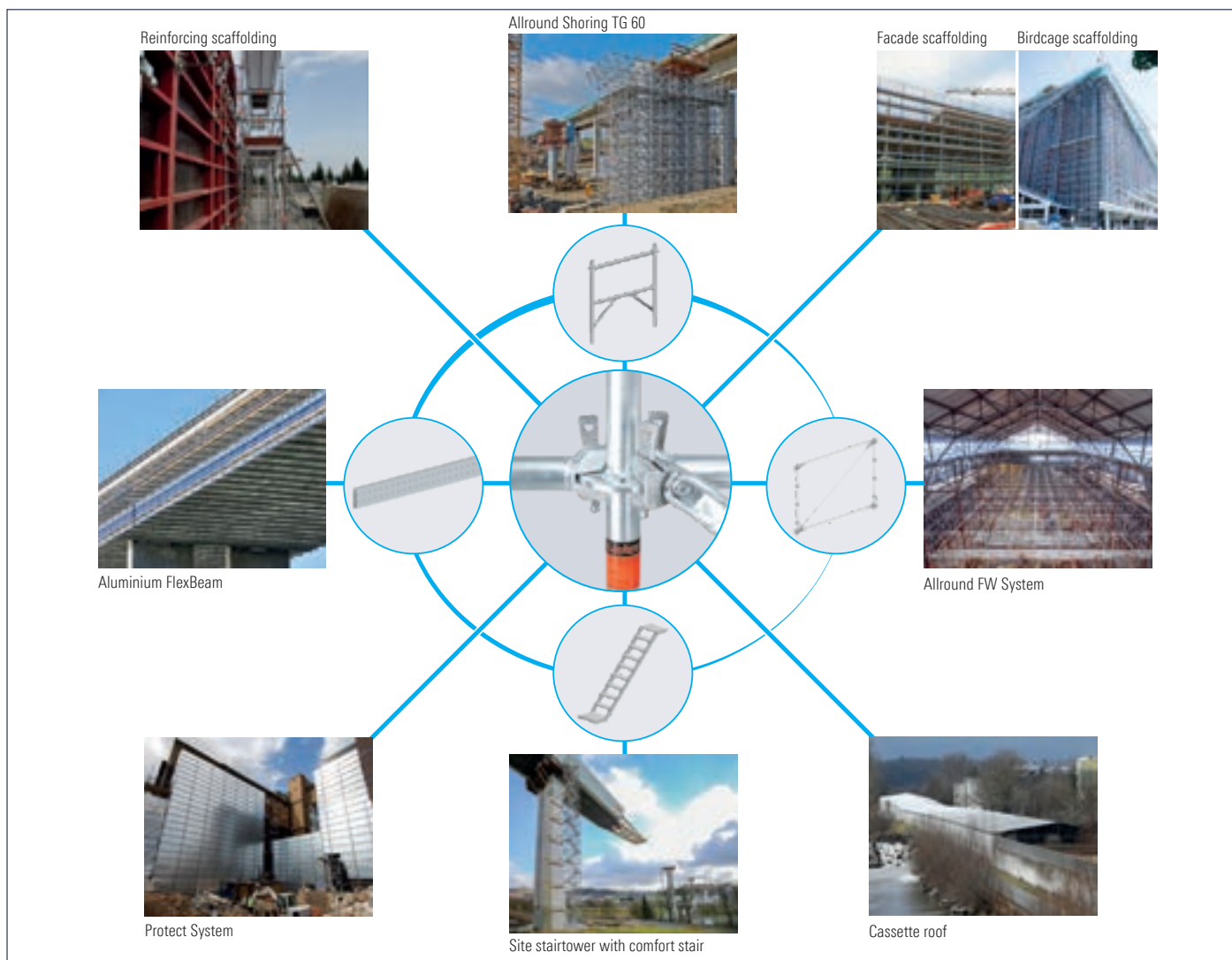

Allround Scaffolding Lightweight from Layher has, with its proven wedge connection technology, heavily influenced scaffolding construction. This original system offers persuasive versatility, in particular for very difficult geometries and anchoring conditions. As scaffolding for working, protection or support, as internal or birdcage scaffolding, or as a rolling tower: there's no job that can't be done more quickly, economically and safely with the Layher Allround system.

- ▶ Higher assembly capacity and better utilisation of transport capacities thanks to weight reduction plus higher load capacity.
- ▶ AutoLock function for even more safety.
- ▶ Economical and material-saving.
- ▶ Integrated system – combinable with other Layher generations, systems and products.

#### With building authority approval

- ▶ Allround Scaffolding made of hot-dip-galvanised steel: **Z-8.22-64**
- ▶ Allround Scaffolding made of aluminium: **Z-8.22-64.1**
- ▶ Allround Scaffolding Lightweight made of hot-dip-galvanised steel: **Z-8.22-939**
- ▶ Combination approval for Allround Scaffolding Lightweight made of hot-dip-galvanised steel with earlier generations: **Z-8.22-949**



#### 4.2.1. Advance Guardrail

With the Advance Guardrail, you can continue to make use of your entire scaffolding stock.

- ▶ Lightweight and complete system made of aluminium – usable with both SpeedyScaf and Allround Scaffolding.
- ▶ Maximum flexibility for assembling, modifying and dismantling, as it is usable even after a scaffolding level has been completed.
- ▶ Consisting of two aluminium Advance Guardrail posts and one aluminium telescoping Advance Guardrail (longitudinal side of scaffolding).
- ▶ Assembled from the secured level directly underneath, without fixed assembly or dismantling direction.
- ▶ The one-piece Advance End Guardrail for the end face of the scaffolding is quickly clamped, using the spring mechanism, between the guardrail of the secured level and the deck ledger of the unsecured level.
- ▶ Matches every scaffolding tube with dia. 48.3 mm.

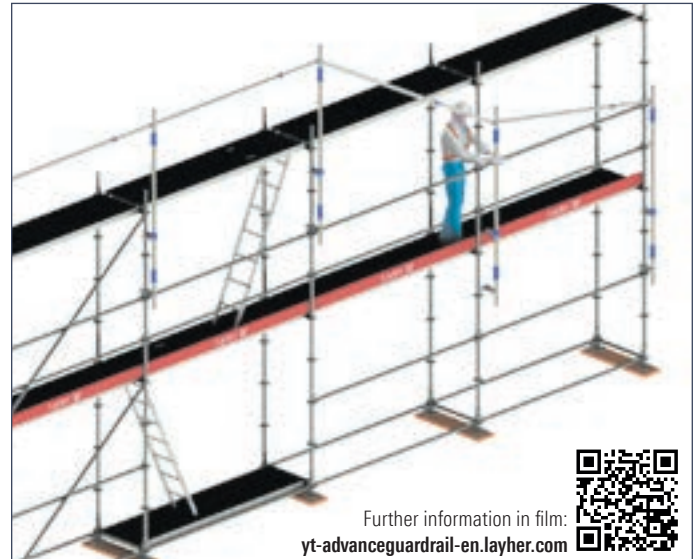

Further information in film:  
[yt-advanceguardrail-en.layher.com](http://yt-advanceguardrail-en.layher.com)

#### 4.2.2. Allround Guardrail System (ARGS)

The Allround Guardrail System permits system-integrated advancing side protection in Allround facade scaffolding, without additional assembly steps.

- ▶ Collective fall protection while working on facade scaffolding using the Allround system.
- ▶ Rapid assembly and dismantling without tools.
- ▶ The ARGS Standard is used on the outside of the scaffolding (optionally on the inside too) instead of a conventional Allround standard.
- ▶ After attachment of the ARGS Standards and ARGS Guardrails over the entire top level, this level now has a complete one-piece or two-piece side protection, and can be safely accessed to permit assembly of the next level.
- ▶ Lightweight and compact components with low transport volume.
- ▶ Remains inside the scaffolding over its entire service life.
- ▶ Subsequent expansion of individual guardrails is possible, regardless of the assembly sequence.
- ▶ External platform stairtowers can be assembled with advancing side protection.

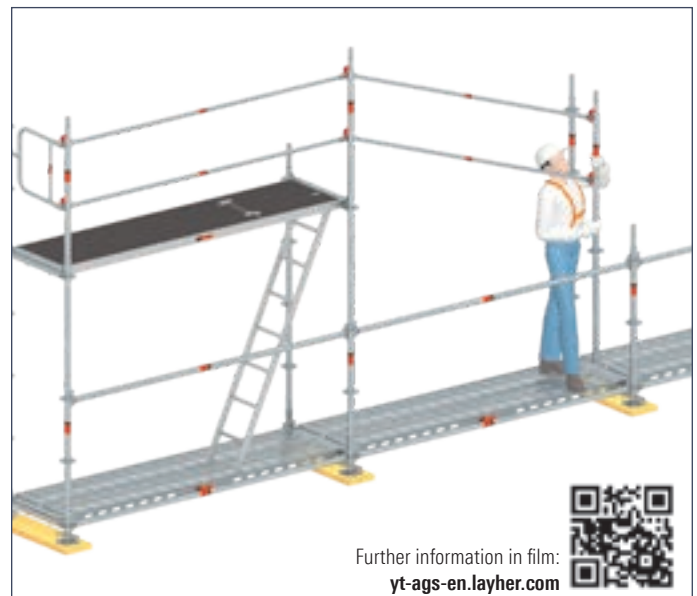

Further information in film:  
[yt-ags-en.layher.com](http://yt-ags-en.layher.com)

#### 4.2.3. Allround Modular Stairtower

The best accident prevention is when a fall is not possible in the first place because work is always done on the ground. For assembly of compact stairtowers, this is possible with the Allround modular stairtower.

- ▶ Safer assembly thanks to level-by-level method followed by crane positioning.
- ▶ Complete towers can be moved using a crane once they have been secured using hinged pins.
- ▶ 20 cm more headroom in a unidirectional stair thanks to the Allround Standard LW 2.21 m.
- ▶ Safer access due to identical step heights – at the crossover too.
- ▶ High flexibility due to option of exit at the front or at the side.
- ▶ Reduced planning effort and greater safety thanks to type structural analysis for assembly heights of up to 115 m.

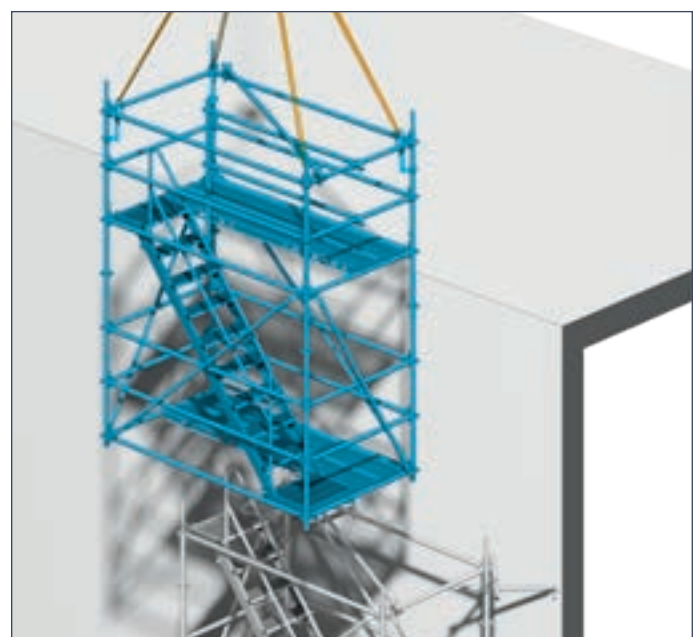

Further information in film:  
[yt-armtt-en.layher.com](http://yt-armtt-en.layher.com)



## 4. Safer working with Layher

### 4.3. LAYHER ALLROUND SHORING TG 60 – THE FLEXIBLE SYSTEM.



For economical, flexible and safer shoring construction, we offer Allround Shoring TG 60. They are centred on the prefabricated TG 60 shoring frames with integrated rosettes and bolt-free wedge head connection.

- ▶ More than 30% time saving during assembly and dismantling when compared with structures made of individual components.
- ▶ Safer upright assembly thanks to integrated advancing side protection.
- ▶ Variable bay lengths for adaptation to the grid dimension of the formwork supports or to the load.
- ▶ Load-bearing capacity of up to six tonnes per standard in shoring towers.
- ▶ Assembly section by section on the ground and then rapid crane positioning.
- ▶ Unrestricted combinability with the Allround Scaffolding range.
- ▶ Stairtowers supplement the system.
- ▶ Easy combination of shoring and work scaffolding is possible.

#### Type-tested

Comprehensive instructions for assembly and use with type-testing of five tower types in various configurations and applications: **TP-11-017**



Further information in film:  
[yt-tg60-en.layher.com](http://yt-tg60-en.layher.com)



Shoring Frame TG 60  
**H = 0.50 m**  
as end frame or equalising  
frame



Shoring Frame TG 60  
**H = 1.00 m**  
as frame in central  
tower area

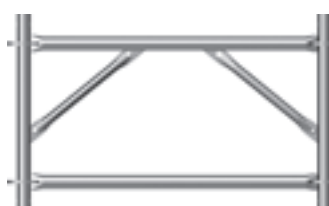

Shoring Frame TG 60  
**H = 0.71 m**  
as initial frame

**4.3.1. Assembly of shoring towers**

- ▶ Safer assembly thanks to innovative assembly sequence, integrated access aid and automatically integrated side protection.
- ▶ Assembly at the site either upright or, thanks to high fitting precision, lying on the ground, for subsequent crane movement.
- ▶ Alternatively, assembled TG 60 towers can also be moved using attached wheels.



Preassembly of TG 60 Shoring Tower on the ground



Crane movement of towers preassembled on the ground



Safer upright assembly thanks to integrated and advancing side protection.

**4.3.2. Integrated deck levels for safer access to slab formwork**

- ▶ Allround Shoring TG 60 permits the laying of a deck level for safer working on the slab formwork.
- ▶ Perforated steel decks with maximum load capacity create a gap-free and non-slip work surface.
- ▶ Easy integration of accesses, such as access bays or platform stairs.
- ▶ Combination of shoring and work scaffolding with one system for uncomplicated implementation of all the latest safety-related requirements.



Integration of stair accesses into shoring structures

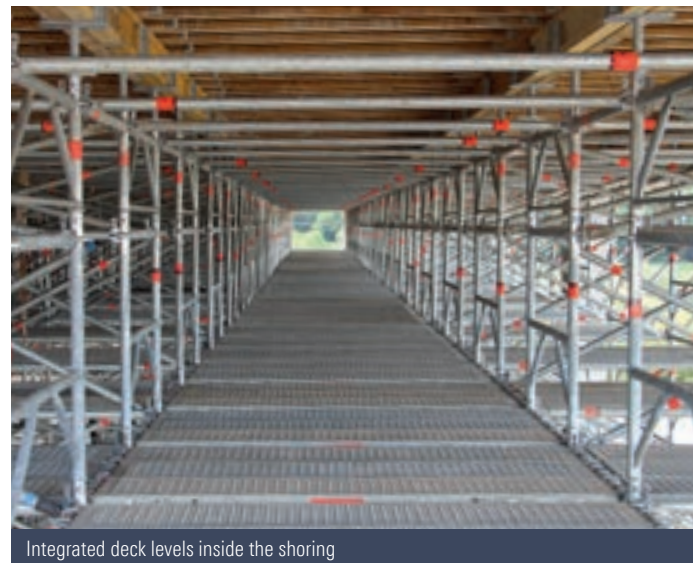

Integrated deck levels inside the shoring



Integration of bracket-mounted walkways in shoring

**4.3.3. Integration of bracket-mounted walkways**

- ▶ The brackets from our extensive expansion part range permit faster and safer assembly of access to formwork with the required side protection.
- ▶ Brackets are also suitable for even better utilisation of the high load-bearing capacity of Allround Scaffolding – for example in projecting shoring structures.

### 4.4. LAYHER PROTECTIVE SYSTEMS



#### 4.4.1. Protect System – Well protected.

The Layher Protect System delivers across the board in terms of environmental friendliness, noise prevention, safety for passers-by and protection against the weather – while offering an attractive appearance. Its dust-tight design makes it the obvious choice for asbestos clearance, facade covering and sandblasting work. Its exceptional acoustic insulation properties make the system also suitable for temporary noise control walls, e.g. at construction sites in urban areas.

- ▶ High-performance solution for increasingly stringent environmental protection legislation.
- ▶ Optimum separation of the construction site and the environment.
- ▶ Reusable cassettes, largely dustproof, weatherproof and suitable for negative pressure.
- ▶ Highly durable, no need for disposal of tarpaulins, extremely cost-effective.
- ▶ High fitting precision, low weight, easy handling.
- ▶ Modular design, compatible with SpeedyScaf and Allround Scaffolding.



Noise and dust protection wall using Protect System, Mercedes Benz Arena, Stuttgart



Road surface repair regardless of weather conditions

### 4.4.2. Keder Roof XL – Lightweight and strong.

The lightweight Keder Roof XL made of aluminium beams with integrated keder section can be assembled both on the ground and directly on the scaffolding. The roof surface is formed from PVC tarpaulins that can be easily inserted into the keder section.

- ▶ Spans up to about 30 m and roof angles of 18° are possible.
- ▶ High snow loads (up to about 1.0 kN/m<sup>2</sup>) with medium spans.
- ▶ Economical solution for both small and large spans.
- ▶ Faster and safer insertion of the keder tarpaulins.
- ▶ Can be used in both SpeedyScaf and Allround Scaffolding.
- ▶ Can also be designed mobile.
- ▶ Wide range of applications, such as roof repairs or roofing over bridges and motorway construction sites.

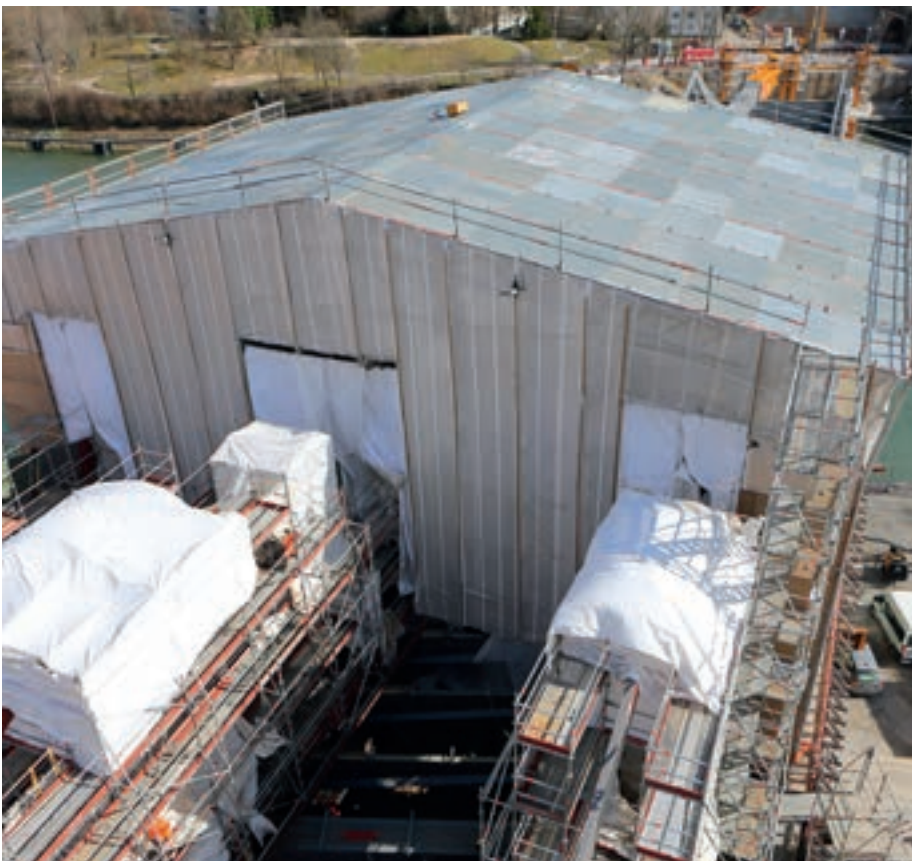

Enclosed formwork carriage during bridge construction

### 4.4.3. Cassette roof – Sturdy and strong.

Inexpensive and labour-saving roofing for weatherproofing and interim halls. The cassette roof is very strong thanks to steel beams and cassettes, making it an investment that retains its value for many years.

- ▶ For conversion work and adding additional storeys, as well as for renovation and restoration work.
- ▶ Roof trusses made from hot-dip-galvanised steel, covered with corrugated-sheet cassettes.
- ▶ Spans up to about 30 m are possible.
- ▶ Pre-assembled on the ground and moved into place by crane.
- ▶ Easy opening of roof cassettes for material supply to the site.
- ▶ Suitable for walk-on access with the appropriate protective equipment.
- ▶ Can be used in both SpeedyScaf and Allround Scaffolding.

# 5. PRODUCTS AND SOLUTIONS

## 5.1. SITE ACCESSES

### 5.1.1. Allround Platform stairtower

Layher platform stairs for sure footing and an agreeable feeling during ascent.

- ▶ Four-standard stairtower for integration into work/ protective scaffolding or shoring.
- ▶ Can be constructed as a free-standing access structure anchored on the building.
- ▶ Thanks to pull-resistant pinning of the standard joints, platform stairtowers can also be assembled suspended and from the top downwards, e.g. using the cut-and-cover method.
- ▶ Parallel and alternating stairs are possible.
- ▶ As an alternative to the platform stair, the tower can also be built with the easy-access comfort stair. The comfort stair ensures additional safety thanks to its wider steps, and a more agreeable feeling during ascent – particularly for great heights.

- ▶ Platform stair: Stair class A as per DIN EN 12811-1.
- ▶ Comfort stair: Stair class B as per DIN EN 12811-1.
- ▶ Permissible load for platform stairtowers: 2.0 kN / m<sup>2</sup>.



Unidirectional platform stairtower



Alternating and suspended platform stairtower



Alternating and suspended platform stairtower



### 5.1.2. Allround Modular stairtower

Suitable as a free-standing or anchored and compact access to high-level workplaces or excavations.

- ▶ Ingenious design with 2.21 m long Allround standards plus standard components from the Allround construction kit with more headroom.
- ▶ Storey-by-storey preassembly on the ground and emplacement using a crane. That means more safety when working and no risk of falls.
- ▶ Stair components identical with the stairs of the platform stairtower or of an external stairtower for facade scaffolding.

- ▶ Platform stair: Stair class A as per DIN EN 12811-1.
- ▶ Comfort stair: Stair class B as per DIN EN 12811-1.
- ▶ Type test for assembly heights of up to 115 m without further verification of structural strength.
- ▶ Permissible load capacity: 2.0 kN / m<sup>2</sup>.



Alternating modular stairtower



Crane movement of a modular stairtower



Access to bridge piers with Allround modular stairtower



Access to bridge piers with Allround modular stairtower

## 5. Products and solutions

### 5.1.3. Compact stairtower

- ▶ The safer stair solution for the building shell.
- ▶ Fits into many stairwells in both single-family houses and residential blocks.
- ▶ Short assembly times with prefabricated and lightweight individual parts.
- ▶ High variability in the heights for entry and exit options in the standard 25 cm grid.
- ▶ Use as work scaffolding for work on the stairwell walls thanks to connection of brackets.
- ▶ Adapter plates permit laying of the screed without having to dismantle the stairtower.

Surface area without brackets:

- ▶ 1.57 x 1.40 m (axis dimension).
- ▶ 1.70 x 1.53 m (outer dimension).
- ▶ Exit clearances: 2.50 or 2.75 or 3.00 m.
- ▶ Permissible load capacity: 2.5 kN / m<sup>2</sup>.



Compact stairtower in a residential block

### 5.1.4. Site stairtower 200

- ▶ Stair constructed from two separate U-stairway stringers 200, with standard decks used as steps.
- ▶ Low weight with wide range of variants.
- ▶ Ideal for use as a convenient access to high-level workplaces and to containers, or as an escape route.

- ▶ Stairway stringer 200, 10 steps, L = 2.57 m, H = 2.00 m.
- ▶ Permissible load 2.0 kN / m<sup>2</sup> with a stair flight width of 1.29 m.
- ▶ Stair dimensions: Riser s = 20 cm.
- ▶ Step width 32 cm (tread a = 24 cm; undercut u = 8 cm).



Site stairtower 200



Site stairtower 200 for access to road surface



Site stairtower 200 for access to road surface, box girders and bridge bearings

### 5.1.5. Stairtower 500 and 750

- ▶ Approved for temporary and permanent stair structures in publicly accessible areas thanks to their permissible load capacities.
- ▶ Typical applications are road crossings, site stairs, escape stairtowers or site stairtowers.
- ▶ Child safety guardrail.
- ▶ Optional continuous handrail and step covers.



Continuous system handrail



Step covers

- ▶ Stairway stringer 500, 9 steps,  $L = 2.57$  m,  $H = 2.00$  m.
  - ▶ Permissible load  $5.0$  kN / m<sup>2</sup> with a stair flight width of  $2.07$  m.
  - ▶ Stair dimensions: Riser  $s = 20.0$  cm.
  - ▶ Step width  $32$  cm (tread  $a = 27.5$  cm; undercut  $u = 4.5$  cm).
- 
- ▶ Stairway stringer 750, 8 steps,  $L = 2.57$  m,  $H = 1.50$  m.
  - ▶ Permissible load  $7.5$  kN / m<sup>2</sup> with a stair flight width of  $2.07$  m.
  - ▶ Stair dimensions: Riser  $s = 16.7$  cm.
  - ▶ Step width  $32$  cm (tread  $a = 31$  cm; undercut  $u = 1$  cm).



Stairtower 750 for container access

### 5.1.6. Temporary bridges / bridging small spans

- ▶ Temporary connections using Allround standard parts and steel decks.
- ▶ Used, for example, for accessing the building shell above the excavation or as an emergency bridge over streams and rivers.
- ▶ Quick to assemble and swing into place by crane.
- ▶ Determination of the span by bay length and number of bays.
- ▶ Standard versions for load class 3 ( $2.00$  kN / m<sup>2</sup>) with optional 3-part side protection.
- ▶ In certain conditions, the free cantilevered method can be used for assembly.



Trench bridge of two Allround Scaffolding bays



Trench bridge of two Allround Scaffolding bays

## 5. Products and solutions

### 5.1.7. Temporary bridges / bridging medium spans

The modular **Allround FW System** was designed for bridging with spans of up to 20 m or to support heavier loads economically. Thanks to uniform system dimensions, it can be completely integrated into the Allround construction kit.

- ▶ Only three supplementary components to the Allround construction kit: FW post, FW chord and FW diagonal brace.
- ▶ High load-bearing capacity thanks to great static height and sturdy parts made of high-tensile steel.
- ▶ Rapid assembly with pin connections.
- ▶ Easy handling thanks to lightweight components of 19 kg maximum.
- ▶ Preassembly on the ground is possible, as is lifting into place using a crane or using the cantilever method from a secured level.
- ▶ Seamless integration into Allround structures is possible, since the components are in the system axes in all three spatial directions.
- ▶ For material-saving scaffolding.

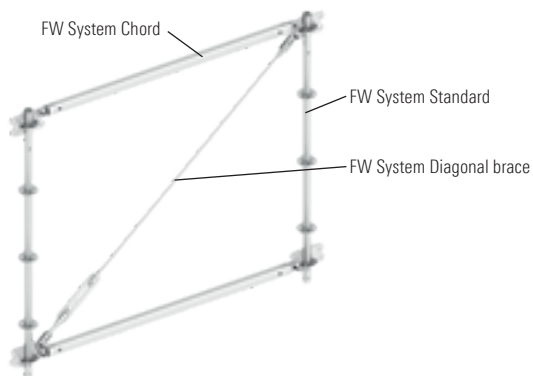

Self-supporting birdcage scaffolding in a shopping centre



Crane movement of an FW System bridging structure

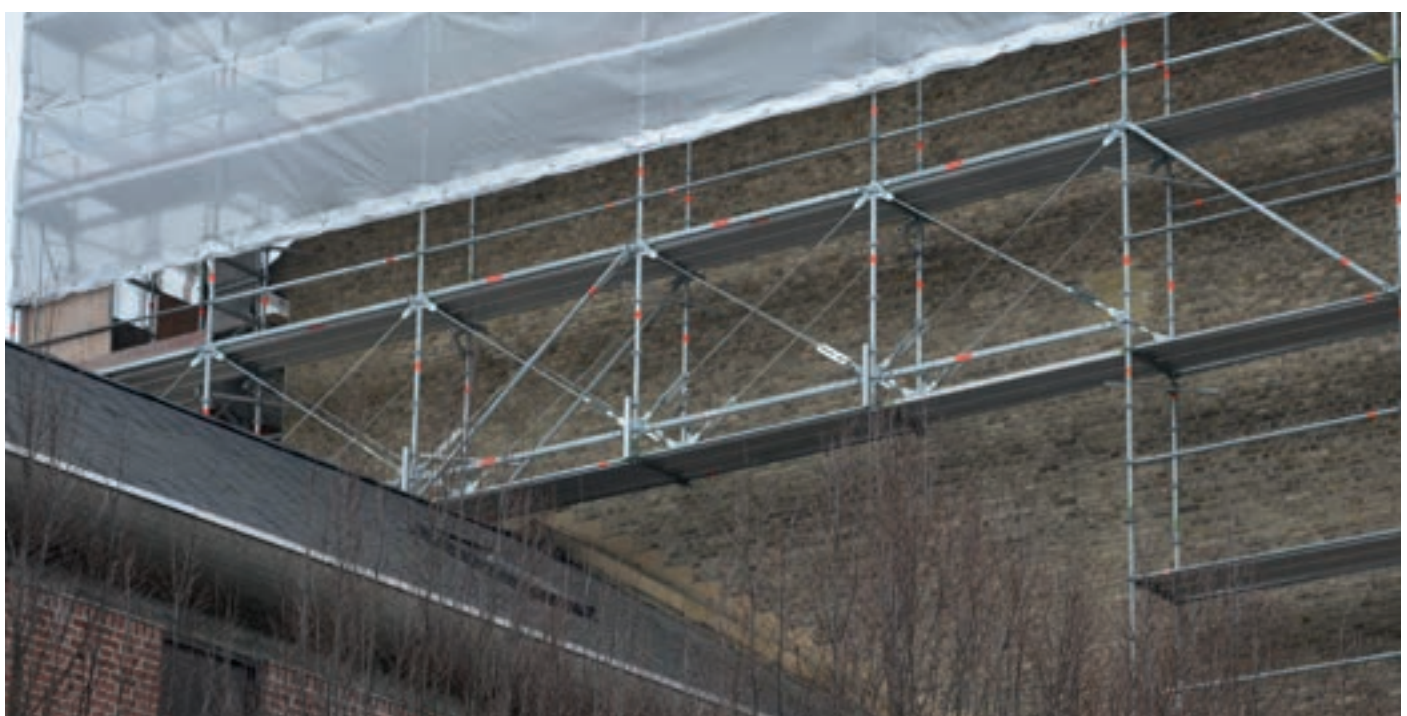

Bridging / supporting of work scaffolding using an external and non-loadable roof

### 5.1.8. Temporary bridges – bridging large spans

Large spans of up to about 30 m can be bridged using the **Allround Bridging System**. This modular lattice system is fully combinable with Layher Allround Scaffolding thanks to the attached wedge heads, and increases its load-bearing capacity.

- ▶ Only a few additional components are needed.
- ▶ Preassembly of the bridge on the ground with simple pin connection technology and lifting into place by crane.
- ▶ Can be combined with a protective systems for roofing and enclosures.
- ▶ Unrestricted combinability with the Allround Scaffolding range.
- ▶ To reduce deformations in the case of wide spans, the beam can be pre-assembled with a deliberate camber.

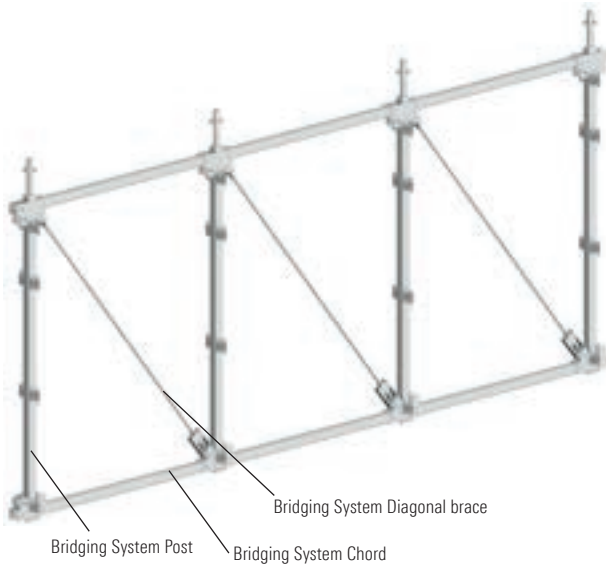

Temporary bridge with approx. 18 metre span



Bridging / supporting of work scaffolding using an external and non-loadable roof



Temporary bridge over site with approx. 18 metre span to assist site logistics

## 5. Products and solutions



Temporary footbridge with a 2x 34 metre span and an intermediate section with Allround Bridging System



Preassembled bridges for subsequent lifting into place by crane



Lifting the temporary bridge into place using a floating crane



Work scaffolding covered using the Protect System on a pipeline bridge for fire damage repair



Temporary footbridge with Protect enclosure and cassette roof



Temporary footbridge using Allround Bridging System with a span of 2 x 31 metres



Temporary footbridge using Allround Bridging System with roofing and Protect enclosure



Temporary footbridge using Allround Bridging System with Stairtower 750 to assist site logistics



Temporary footbridge using Allround Bridging System on railway platform with Stairtowers 750 and internal Protect enclosure

### 5.2. REINFORCING, CONCRETING AND WORK SCAFFOLDING



Free-standing SpeedyScaf – stability thanks to stabilisers

#### 5.2.1. Reinforcing and concreting scaffolding

The Layher scaffolding systems permit:

- ▶ Unhindered access to the wall and beam reinforcements without anchoring.
- ▶ Stability is assured by simple bracing and, where applicable, by widening the base.
- ▶ Accesses to all relevant components can be constructed with matching bay lengths.
- ▶ Inner guardrails and brackets provide safety even at a large distance from the wall.
- ▶ Attachment of the Advance Guardrail on both sides of the scaffolding ensures a high degree of safety during assembly itself.
- ▶ It can be moved by crane at any time thanks to pull-resistant pinning of the standard joints.

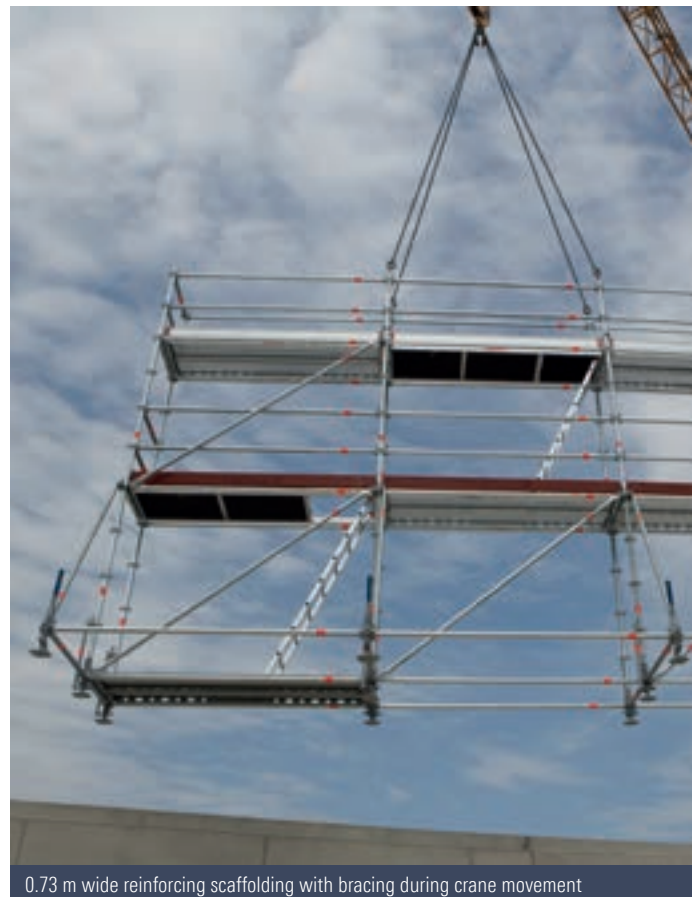

0.73 m wide reinforcing scaffolding with bracing during crane movement



1.40 m wide reinforcing scaffolding with bracing



### 5.2.2. Work scaffolding

SpeedyScaf provides, with a few basic elements, a stable base for all work on the facade.

- ▶ Recommended in particular for length-oriented facade scaffolding.
- ▶ Rapid assembly.
- ▶ The I-Guardrail permits assembly with integrated and advancing side protection.
- ▶ A wide and well thought-out range of parts makes countless applications and expansions possible.
- ▶ Easy assembly of integrated platform stairs.

SpeedyScaf has received building authority approval from DIBt as facade scaffolding under the numbers:

- ▶ Z-8.1-16.2 (System 70 Steel).
- ▶ Z-8.1-840 (System 100 Steel).
- ▶ Z-8.1-844 (System 70 Aluminium).



SpeedyScaf facade scaffolding with I-Guardrail



Facade work scaffolding of Layher SpeedyScaf resting on a projecting beam system to ensure continued vehicle access

## 5. Products and solutions

Allround Scaffolding, with its high adaptability, is ideal for very irregular structures.

- ▶ Persuasive advantages, particularly for projections and recesses, protrusions and niches.
- ▶ Economical and material-saving.
- ▶ Meets a wide variety of requirements for work and protective scaffolding.
- ▶ With the Allround ARGs system, facade scaffolding using Allround Scaffolding can be assembled with integrated and advancing side protection.
- ▶ Integrated stair accesses for non-fatiguing ascent and easier transport of materials and tools.

Allround Scaffolding has received building authority approval from DIBt as facade scaffolding under the numbers:

- ▶ Z-8.22-64.
- ▶ Z-8.22-939.
- ▶ Z-8.22-949.



Allround work scaffolding with Allround Guardrail System



Allround work scaffolding in a complex terrain geometry, with integrated stair access

### 5.2.3. Concreting scaffolding with cavity wall brackets

Concreting work on cavity walls requires access to the walls from above. Due to the push-pull props needed, it is often not feasible to work with conventional standard scaffolding here. Thanks to the cavity wall bracket adapter, bracket-mounted walkways made of standard Allround Scaffolding material can be constructed.

- ▶ Variably adaptable in height and bay length, so that the space needed for the angled props can be kept clear.
- ▶ Non-slip steel decks.
- ▶ 3-part side protection (also possible all around the circumference of the wall).
- ▶ Rapid assembly thanks to the proven Allround wedge connection technology.



1.09 m wide concreting scaffolding with cavity wall bracket adapter

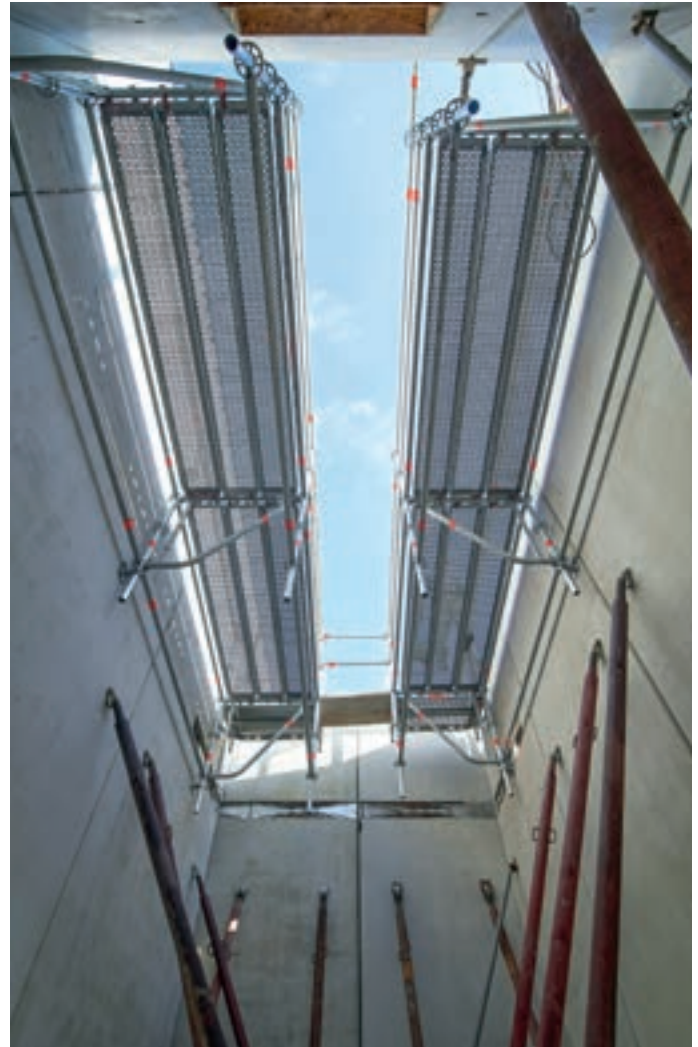

The space underneath the scaffolding remains free for the push-pull props



1.09 m wide concreting scaffolding with cavity wall bracket adapter

## 5. Products and solutions

### 5.2.4 Work scaffolding, free-standing and suspended for complex geometries

Work platforms at piers, bridge caps and on the underside of bridges can be provided with free-standing or suspended scaffolding. This ensures that every point on the bridge can be reached. The modular Allround construction kit permits adaptation of work scaffolding to any geometry – regardless of projections, protrusions or supports. Allround Scaffolding is also ideally suited as an access to the formwork carriage.



Free-standing work scaffolding on stone arched bridge



Suspended bridge underside scaffolding of lattice beams



Suspended bridge underside scaffolding with protective wall on aluminium FlexBeam



Work scaffolding inside box girders of bridge structure

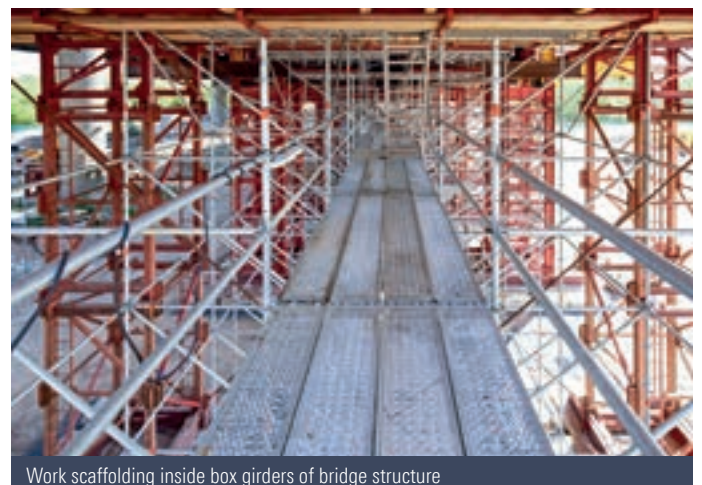

Work scaffolding inside box girders of bridge structure



Enclosure of bridge piers as access to the formwork carriage



Mobile bridge cap scaffolding

For an extremely economical solution for work scaffolding at bridge caps, the suspended work scaffolding can also be designed mobile. In this case, they rest on rails provided on the bridge surface.

- ▶ The scaffolding structure can always be moved to wherever it is currently needed.

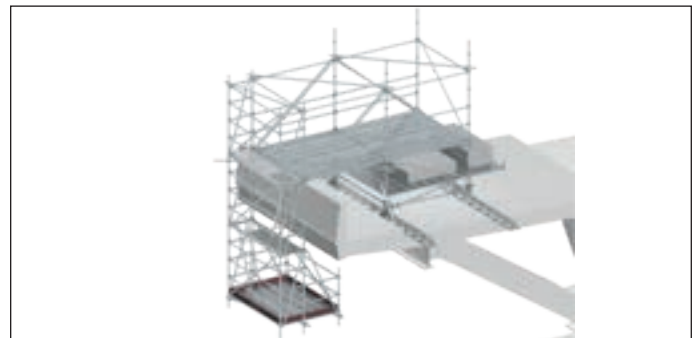

Mobile bridge underside scaffolding made of Allround system components

## 5. Products and solutions

With the **Allround Bridging System** or the **Allround FW System** work scaffolding can also span even large distances in a self-supporting manner, without the need for intermediate support for the scaffolding. As a result, the scaffolding does not have to be completely resting on the ground, which is often not possible for topographical reasons.



Free-standing work scaffolding on a stone arched bridge with Allround Bridging System for support

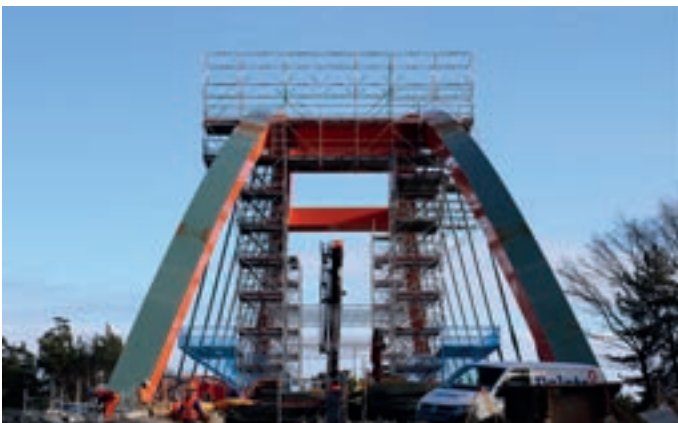

Self-supporting work scaffolding between the arches of an arched bridge with Allround FW System

As underside scaffolding on bridges, it is also possible with the **Allround FW System** to construct closed work platforms which are fastened to the bridge with only a few individual suspension points.

- ▶ The structure shown adjacently is connected only by two threaded rods to a traction vehicle on the upper side of the bridge which moves the work platform to the place required.



Mobile bridge underside scaffolding using Allround FW System and system decks

For large-area and suspended bridge substructures with high load-bearing capacities, the Aluminium FlexBeam is the ideal solution.

- ▶ The U-shaped upper side of the section permits direct suspension of standard U-decks.
- ▶ The hole configuration permits problem-free further construction using Allround Scaffolding material.
- ▶ Bending load capacity is up to 2.5 times as the Steel Lattice Beam 450 LW, permitting larger support and suspension configurations.
- ▶ Only 280 mm structural height, about 40% less than with the Steel Lattice Beam 450 LW.
- ▶ The headroom for trucks is retained at motorway bridges.



Bridge underside scaffolding with protective wall made from Aluminium FlexBeam



Bridge underside scaffolding with two levels made from Aluminium FlexBeam at a viaduct



Work scaffolding with pedestrian tunnel with FlexBeam and Protect enclosure



Approx. 7000 m<sup>2</sup>-sized bridge underside scaffolding with FlexBeam at a steel composite bridge



Mobile tunnel scaffolding running on rails

### 5.2.5 Tunnel scaffolding for reinforcing work and further treatment

Work on tunnel ceilings for reinforcement or other treatments require a work platform that adapts to the curving tunnel ceiling. No problem at all with flexible Allround Scaffolding.

- ▶ Moving to keep pace with the building progress, reducing the use of material to what is necessary for structural strength and design reasons.
- ▶ Wheels of differing load capacity, including rail-mounted flanged wheels, ensure a mobile scaffolding structure for a wide range of applications.
- ▶ The lightweight parts enable the structures to be transported even to places of use with difficult access and assembled there without problem.
- ▶ Preassembly of complete scaffolding units and subsequent crane movement to where they are used is possible even with large scaffolding.



Previous emplacement of a preassembled mobile tunnel scaffolding by crane



Mobile tunnel scaffolding running on rails with work platforms for safer working





Mobile work scaffolding adapted to the tunnel geometry, with vehicle passage opening



Shoring TG 60 and suspended birdcage work scaffolding made from Steel Lattice Beams 450 and system decks

### 5.3. SHORING

#### 5.3.1. Allround Shoring TG 60

Together with Layher Allround equipment, the TG 60 shoring frames create even more possibilities. With Shoring TG 60, shoring can be built more than 30% faster, higher, more stable and safer. The Shoring Frames TG 60, available in three sizes, are made from extra-strength steel tubing and provided with Allround rosettes. The TG 60 frames are an integral part of Allround Scaffolding and can be integrated without problem into any birdcage scaffolding. **Each standard of a TG 60 shoring tower can be subjected to a load of up to 6 tonnes.** Connecting up the shoring towers TG 60 using Allround ledgers makes time-consuming measurement unnecessary. The towers are automatically at right angles to one another, further reducing the risk of tipping over.



Connected shoring towers TG 60 during construction of a sewage plant – concrete pillars can simply be integrated into the shoring.

- ▶ The TG 60 shoring towers can be adapted without problems to any specific factors of the structure, terrain or configuration dimension of the formwork supports.
- ▶ The ground plan results from the 1.09 m wide frames and the Allround ledgers used, from 1.09 m to 3.07 m.

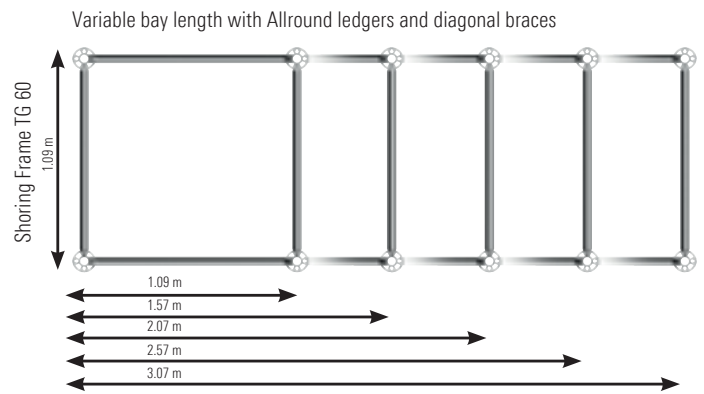

- ▶ Assembly with the innovative assembly sequence and the integrated access aid can be performed free-standing directly at the place of use. During assembly, you are always surrounded by an automatically integrated side protection – without any further safety equipment.
- ▶ Fully assembled towers can be moved using easy-to-fit wheels.
- ▶ Alternatively, TG 60 shoring towers can also be assembled lying on the ground, thanks to their high fitting precision, for subsequent crane movement.

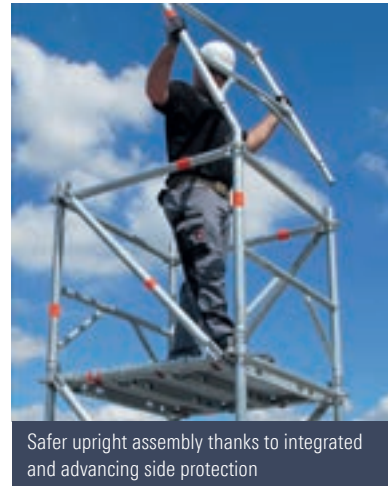

- ▶ Height adjustment at the top and bottom, and geometry adaptations at the edge, can easily be done using the Allround construction kit.

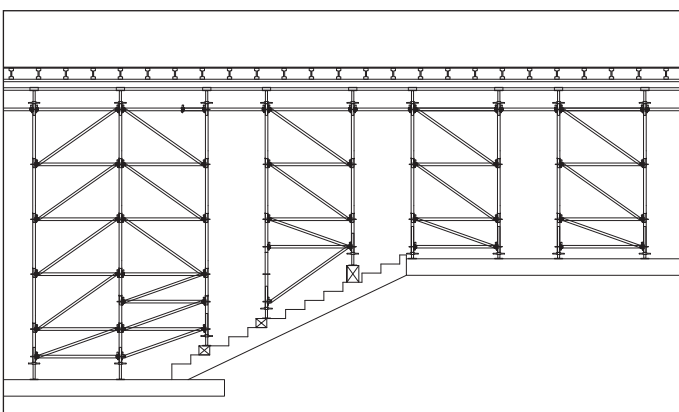

## 5. Products and solutions

Allround TG 60 Shoring permits the laying of a deck level for safer working on the slab formwork.

- ▶ Practical and non-slip work surface thanks to perforated steel decks with maximum load-bearing capacity.
- ▶ Easy integration of accesses in the form of access bays or platform stairs.
- ▶ Combination of shoring and work scaffolding with one system for uncomplicated implementation of all the latest safety-related requirements.



Integrated deck levels inside the shoring, and shoring adapted to the slope of the ground using equalising plates

Shoring with truck access is possible even without the use of bridging structures with heavy steel beams. Simple lattice structures can bridge the usual access widths of around 4 – 5 m.

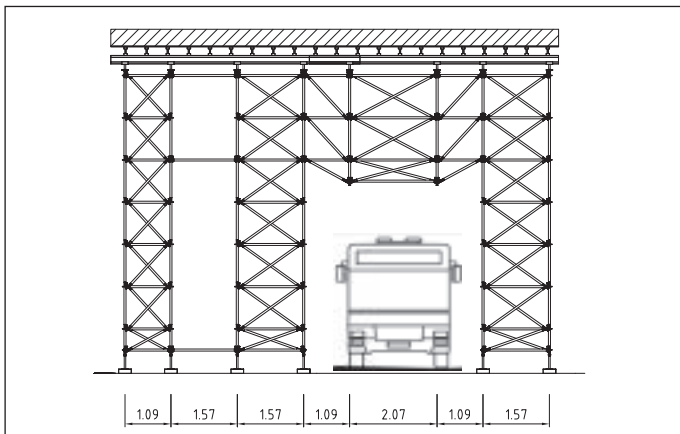

Vehicle passage opening thanks to the use of Allround standard material

For very heavy loads, the shoring towers can be reinforced by additional frames. Combining frames allows the load capacity to be increased to almost any level. The picture shows shoring for absorbing a line load of 250 kN / m.

- ▶ The 0.80 m intermediate spindle thus increases the total spindle travel from 26 cm to 64 cm at the top of the tower.
- ▶ This additional 38 cm allows precise adjustments during height equalisation of linked towers at the top of the towers, simplifying both planning and assembly.

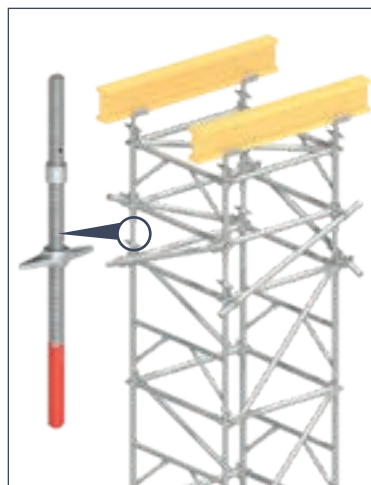

Frame combination for absorbing high loads

Concreting of building projections is not a problem, even at great heights, thanks to the modular Allround system.

- ▶ The towers are braced using system components, i.e. without time-consuming constructions made of pipes and couplers.
- ▶ Bracket-mounted walkways with side protection at their edges are quick to assemble.



Projecting Allround Shoring Towers TG 60



Stretched shoring tower TG 60 for supporting a balcony slab



High support towers made from Allround Shoring TG 60 with system-integrated bracket-mounted walkways

When the prefabricated ceiling slabs (e.g. for balconies or arcades) are lifted into place, the TG 60 shoring towers ensure the necessary stability instead of single supports.

- ▶ Shoring towers that are connected to one another are per se non-positively connected, allowing the prefabricated slabs to be shifted into their exact position.

## 5. Products and solutions



The variable system also permits support in the manufacture of tall and wall-like concrete beams cast in-situ, with semifinished ceiling slabs laid between them. Material optimisation by absorbing the ceiling loads using a latticework of Allround standard components between the shoring towers. No need for additional towers in the intermediate spaces.

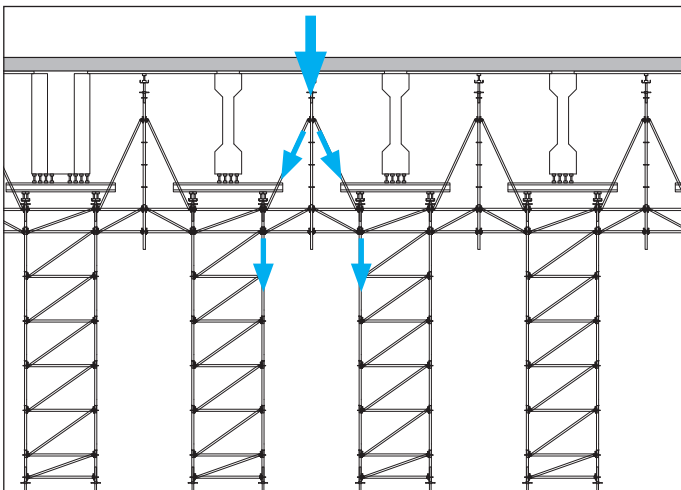



Shoring TG 60 can be used as a substructure for pre-assembled slab tables.

- ▶ Time-saving movement of complete units by crane thanks to a pull-resistant connection of the head jacks to the slabs. Solution shown on request.
- ▶ With attached wheels, the slabs can be moved horizontally inside a storey level.



Shoring TG 60 as a slab table with pull-resistant connection of the formwork to the shoring towers

## 5. Products and solutions



The challenge with this shoring structure was a crosswise-pretensioned slab structure for supporting a high-bay warehouse.

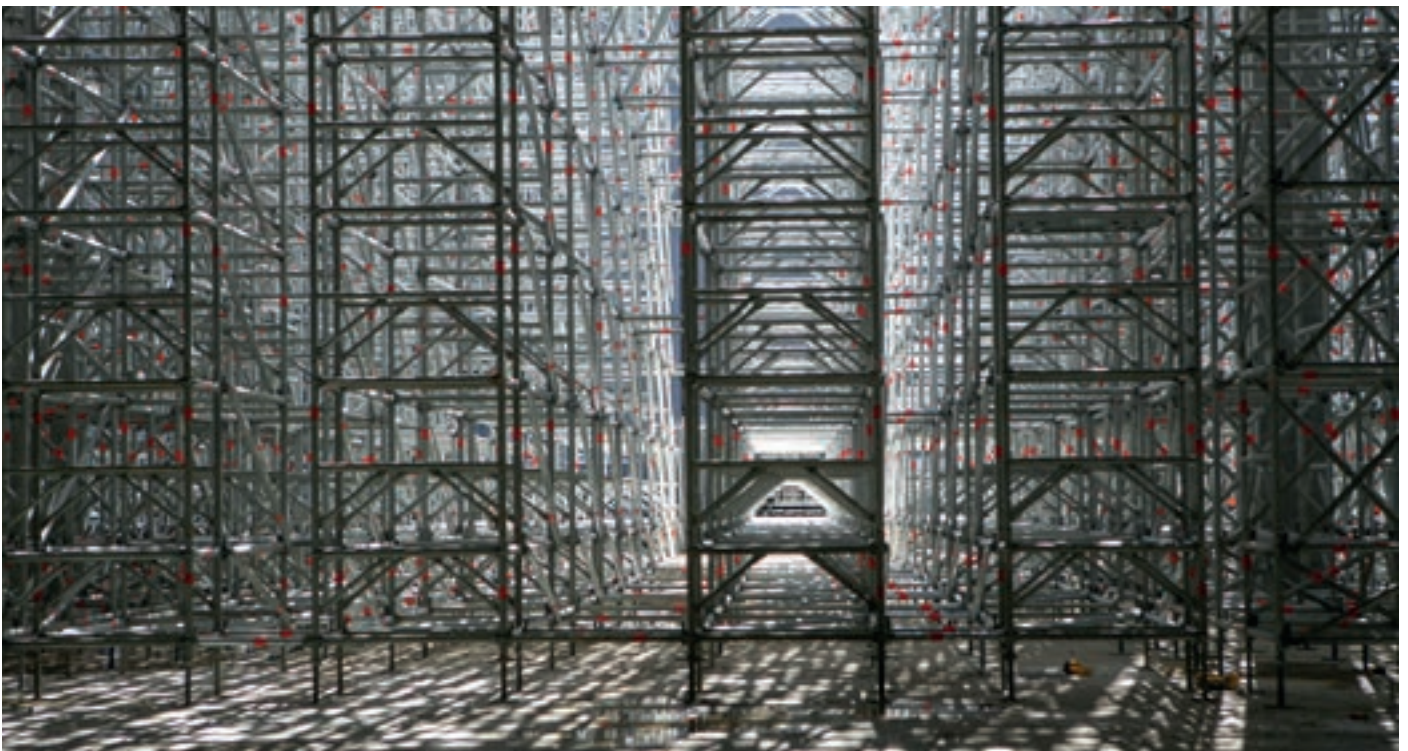

With the modular and flexible construction kit system of Allround Shoring TG 60, it can be used for several building phases without extensive modification work. In this example, the binding beams are concreted in a first step, and the ceiling resting on them in a second step.

- ▶ Integrated decks reduce the risk of falls.

Assembly in the system grid using Allround standard parts enables alignments to be perfectly maintained without time-consuming measurement.

- ▶ Absolute fitting precision ensures a smooth implementation of planning work at the construction site.



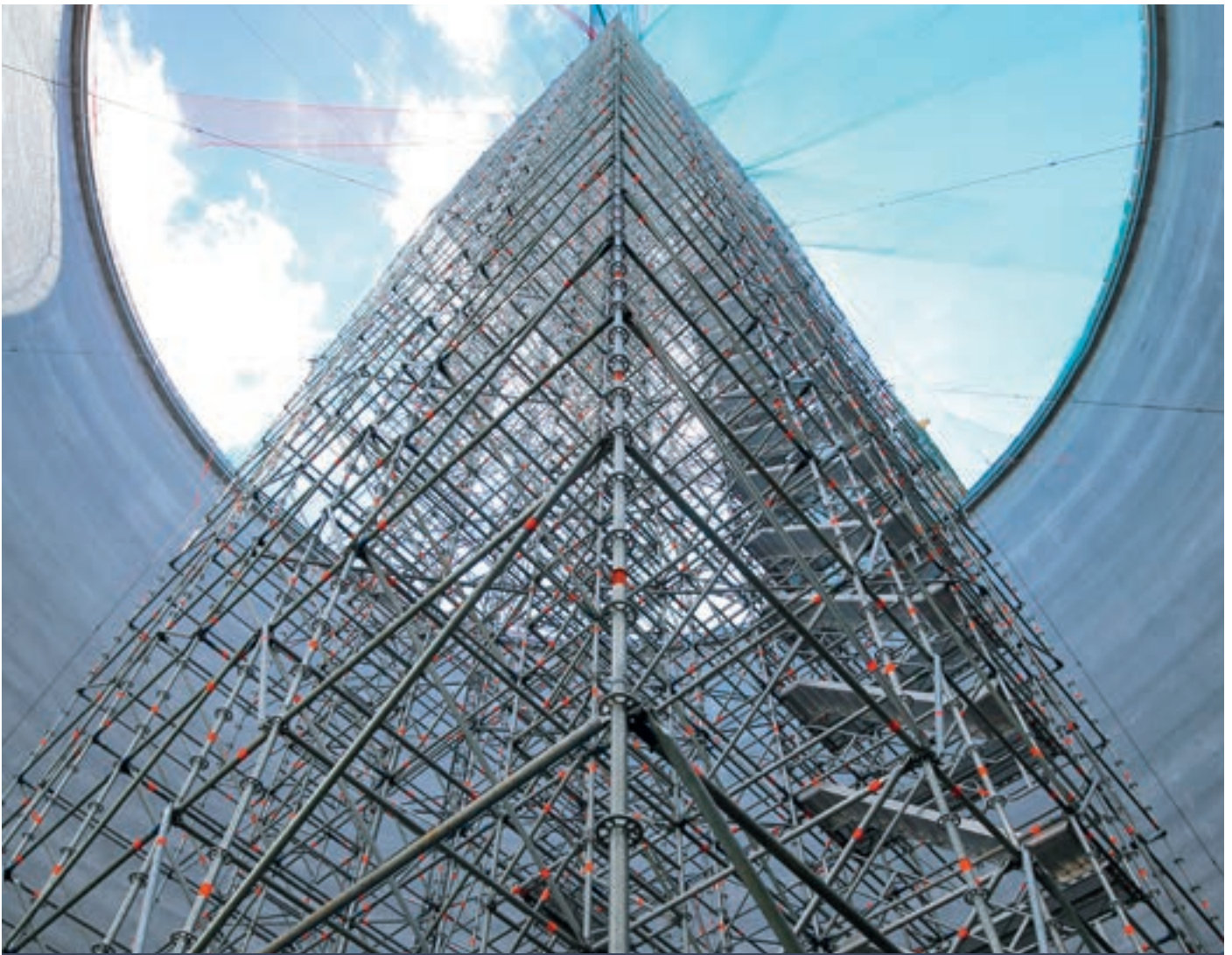

Allround Shoring Frame TG 60 with integrated platform stair accesses during construction of a new sugar silo



Combination of Allround Shoring Towers TG 60 for concreting of a projection — fast and convenient site access with Allround modular stairtower

## 5. Products and solutions

With Allround Shoring TG 60, supporting structures for concreting work on massive floors can be constructed easily, quickly and safely. Combining shoring frames enables the load capacity to be multiplied many times over. Large support heights can be managed without problem.

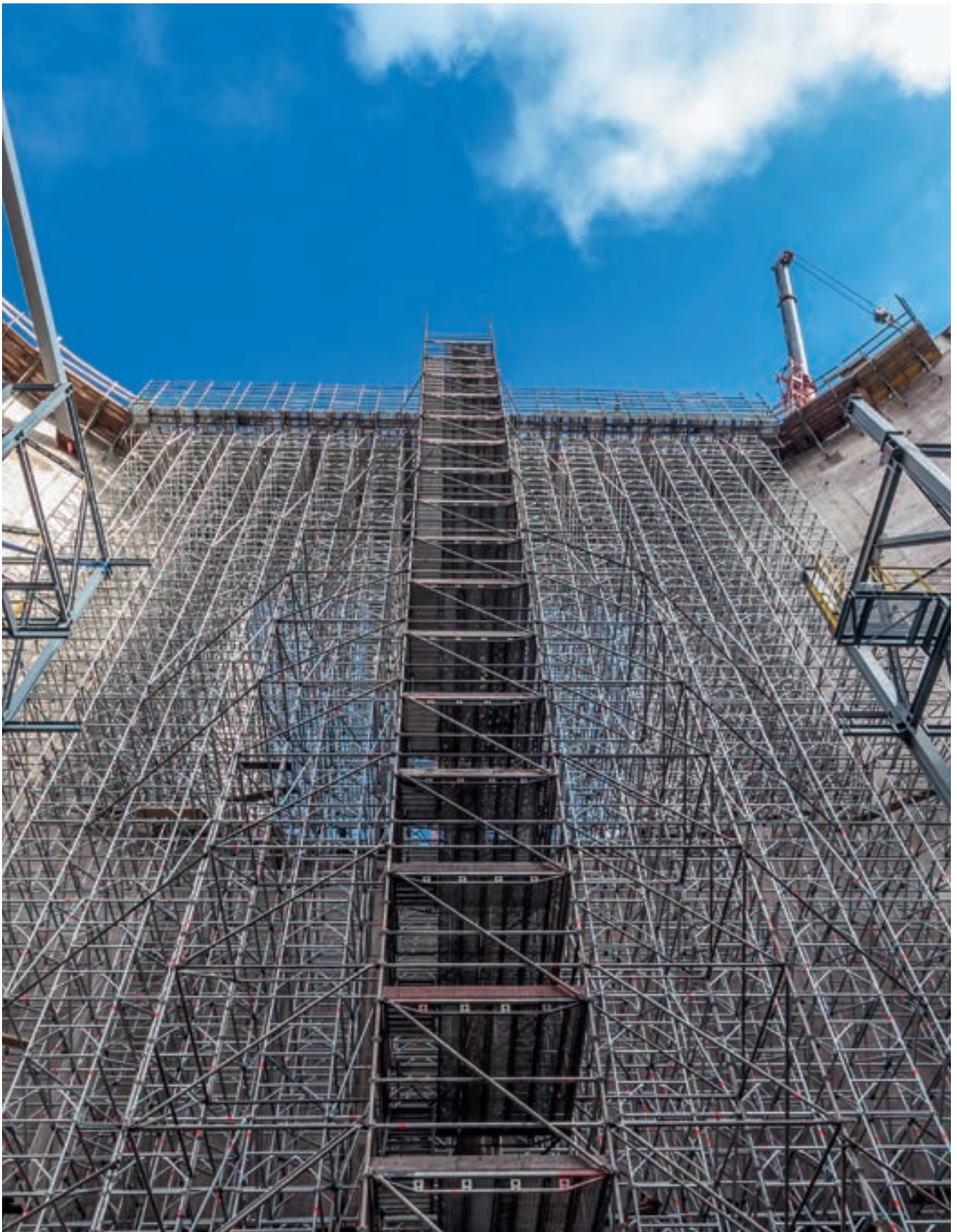

Combination of high Shoring Towers TG 60

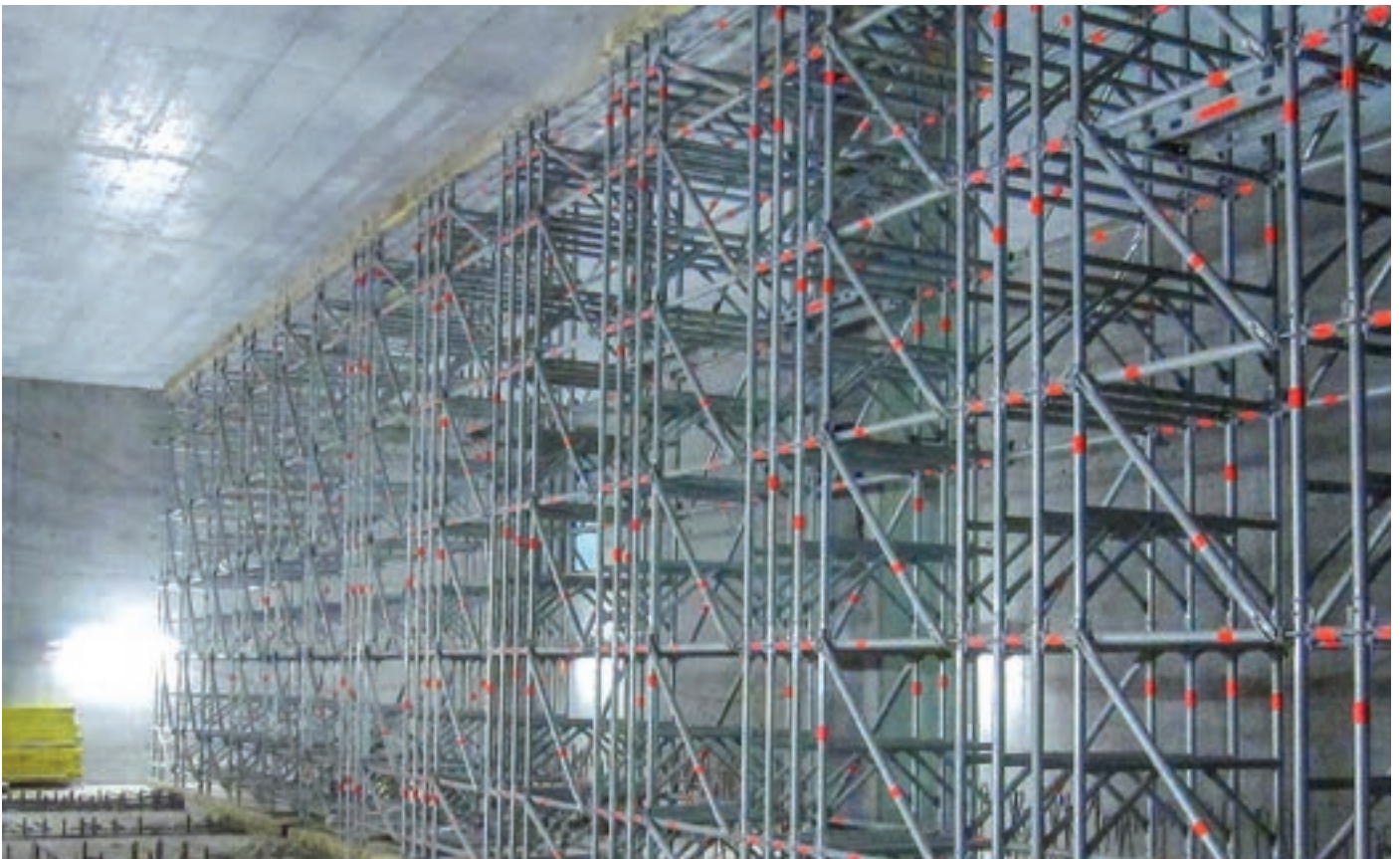

Frame combination for absorbing high loads of 22 tonnes per metre



Allround Shoring Frame TG 60 with integrated FW System for vehicle passage opening

The use of the **Allround FW System** enables vehicle passage openings to be constructed at all structurally relevant positions.

- ▶ No restriction of the supporting structure.



Shoring TG 60 for tunnel concreting work

## 5. Products and solutions

### 5.3.2. Combination of Allround Scaffolding and Shoring TG 60

Allround Scaffolding with its extensive range of standard parts can, depending on requirements, also be used for shoring. The Lightweight variant in particular, approved according to Z-8.22-939, is notable for its high load-bearing capacity.

- ▶ With Allround Shoring TG 60, support structures for concreting work on bridge superstructures can be constructed easily, quickly and more safely.
- ▶ The TG 60 frames can be integrated into any Allround birdcage scaffolding to increase its loading capacity.
- ▶ The birdcage scaffolding is braced using system ledgers and diagonal braces, instead of time-consuming tube and coupler connections.
- ▶ Integrated stair accesses or all-round bracket-mounted walkways are quick and easy to assemble.
- ▶ The easy combination enables adaptation to the most difficult geometries while absorbing very high loads.

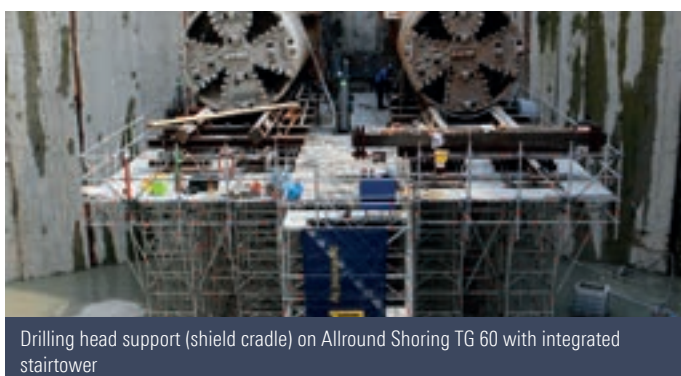



Shoring made from standard Allround components during construction of a new motorway bridge



Shoring made from Allround Shoring TG 60 and Allround Scaffolding during construction of a road bridge

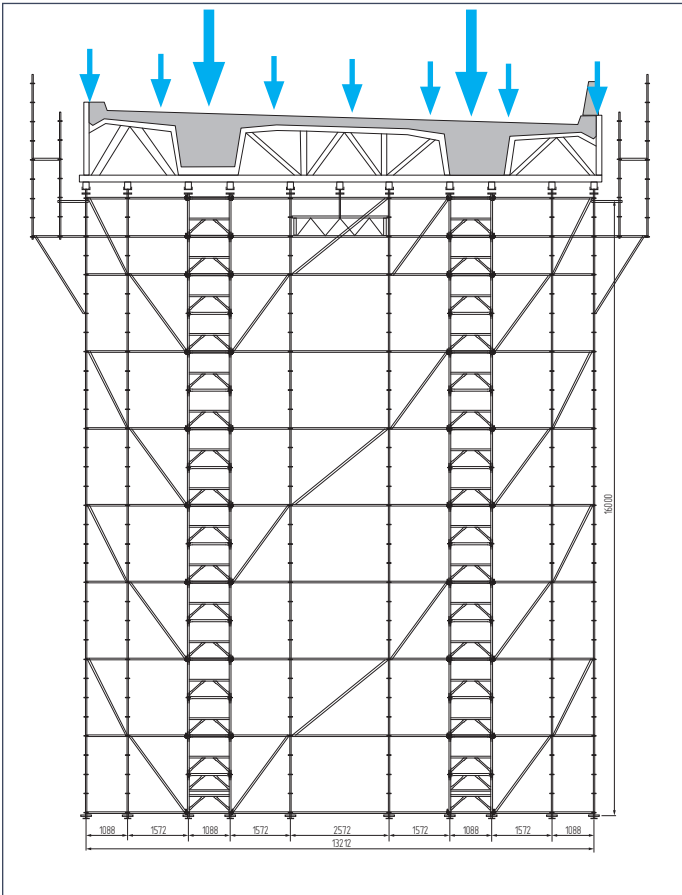

## 5. Products and solutions

### 5.3.3 Allround heavy-duty column

Combining four Allround standards using twin edge couplers allows very high point loads of up to around 200 kN (20 t) to be absorbed by the birdcage scaffolding. The individual support can be used vertically, horizontally or inclined.



Heavy-duty support during bridge construction



Allround heavy-duty column as a support for a temporary weather protection roof



Shoring made of several combined heavy-duty columns in bridge construction

### 5.3.4. Allround Heavy-Duty Tower XL

For some construction projects, shoring of particularly high load capacity is needed, as very high loads have to be absorbed at some points – for example in bridge construction. Here, the Allround Heavy-Duty Tower XL is the persuasive alternative to the usual heavy shoring structures made from steel sections.

- ▶ Modular assembly, based on standard Allround Scaffolding parts.
- ▶ Load absorption of up to 200 tonnes depending on the conditions of its use.
- ▶ A few lightweight supplementary parts enable load-bearing capacities in the Meganewton class to be attained.
- ▶ Advantages when dismantling without a crane, since the compact components can be individually removed and transported.
- ▶ Repositioning of integrated work platforms and accesses is possible.



Lowering wedge on Heavy-Duty Tower XL

The load is introduced at the top via a solid steel plate. The top plate can be easily connected to the steel beams using beam clamps. The load on the tower is relieved using lowering wedges or a hydraulic press, provided by others.

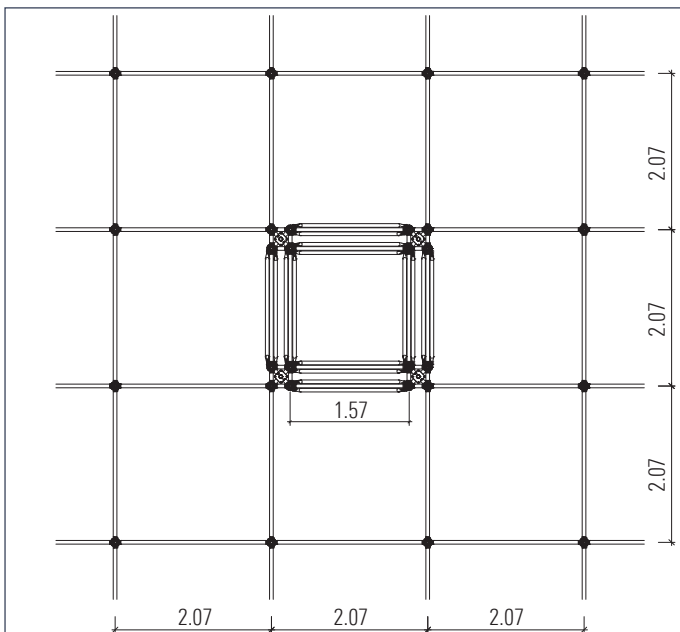

Dimensionally integrated into the Allround System

The standard assembly version has the following axis dimensions:

- ▶ Inside: 1.57 m x 1.57 m.
- ▶ Outside: 2.07 m x 2.07 m.

The respective version must be structurally verified in each individual case.

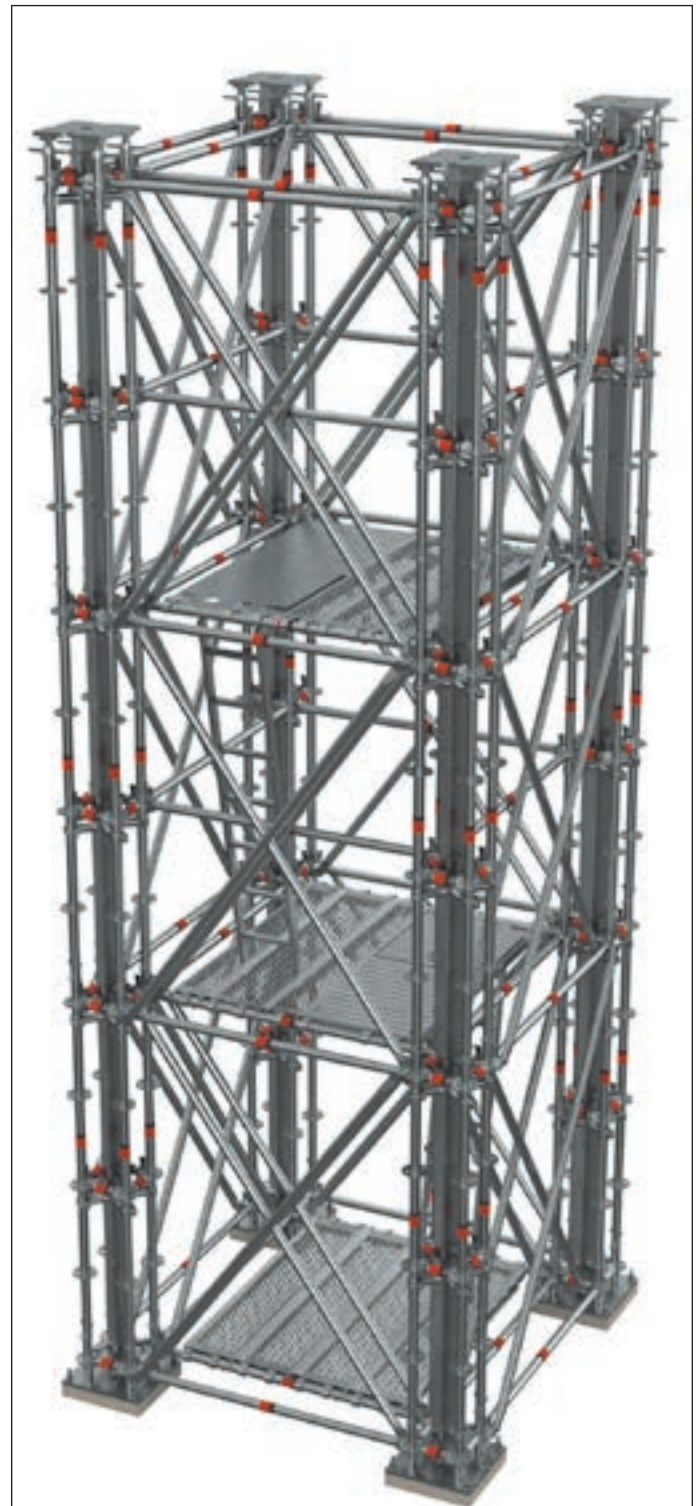

Heavy-Duty Tower XL

5.4. SITE PROTECTION



Bridge pylon enclosed using Protect System during sandblasting work



### 5.4.1. Protect System

With the Protect System, Layher can supply a reusable cassette enclosure system that is compatible with Allround Scaffolding and SpeedyScaf and that meets requirements relating to environmental protection and insulation from noise and weather; an exceptionally economical solution in Layher's proverbial high quality.

- ▶ Enclosing work scaffolding with the Protect System provides protection against dropped work materials or against blasting materials during corrosion prevention work.
- ▶ Traffic can continue to flow despite repair work to bridge piers, pylons or supporting cables.



Bridge work scaffolding enclosed with cassette roof and Protect System



Temporary hall using Allround Scaffolding, Protect System and cassette roof

## 5. Products and solutions



Modernising measures while clinic is still operating



Noise control wall for reducing traffic noise



Noise control / dustproof wall during demolition work

The modular Protect System consists of cassette elements which are easily fitted to the scaffolding and optionally provided with a galvanised steel sheet or a translucent plastic ribbed panel.

- ▶ Dustproof, weatherproof and noise-reducing partition wall between the site and the environment.
- ▶ All-round rubber seal for a neat and precisely fitting connection to the adjacent elements.
- ▶ Protects passers-by from dust, noise and harmful substances.

### Technical Data:

- ▶ Thermal insulation of light cassette:  $3.3 \text{ W} / \text{m}^2 \text{ K}$ .
- ▶ Airborne sound insulation of wall cassette:  $R'w = 26 \text{ dB}$ .

### 5.4.2. Scaffolding tarpaulins and nets

Layher offers an extensive range of scaffolding tarpaulins and nets, which can be fitted quickly and easily thanks to non-system accessory parts.



Cable-stayed bridge pylon covered by tarpaulins

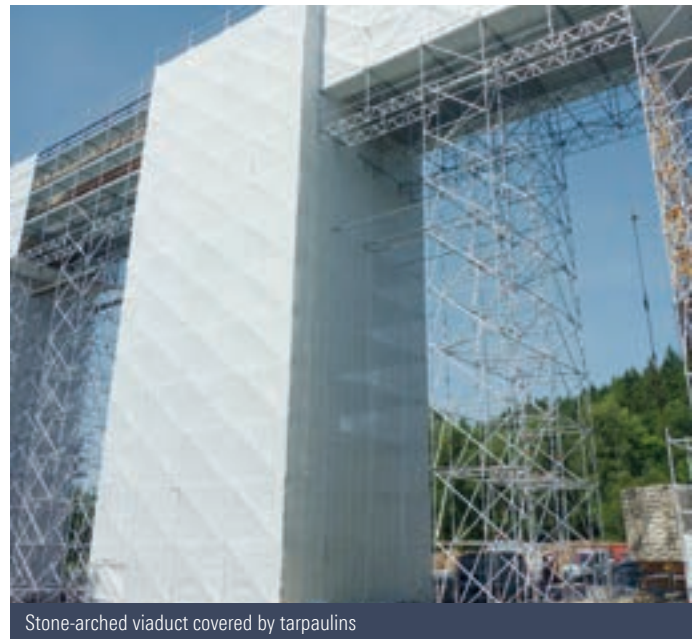

Stone-arched viaduct covered by tarpaulins

### 5.4.3. Weather protection roofs

There may be many reasons to use a weather protection roof: Work on buildings, bridges or roads can be done despite rain or snow, and roof work can be carried out and new storeys added while the building is still in use. Layher offers the right solution for a wide range of applications. For small, medium or very large spans – even with snow loads.



Weather protection roof during construction of an animal enclosure

The **Layher cassette roof** has established itself as a firm favourite at construction sites for conversion, added storeys, renovation and restoration.

- ▶ The structure itself and all the equipment is protected during conversion or roof repair work, and normal business operations can continue under a secure roof.
- ▶ Wide spans, walk-on roof surfaces and the option of opening the roof at any point are further crucial advantages.

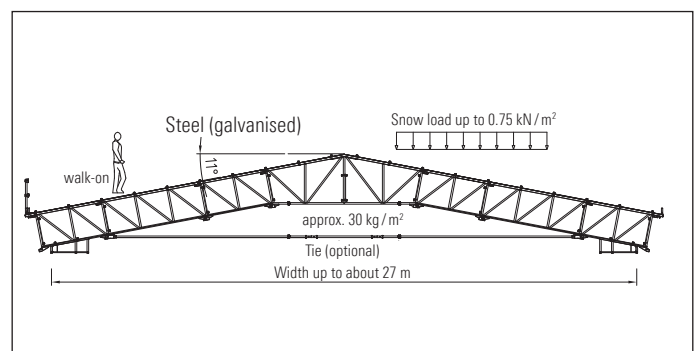

## 5. Products and solutions



Keder Roof XL on SpeedyScaf for wintertime road construction work



Keder Roof XL for wintertime foundation concreting work



Keder Roof XL for wintertime timber construction work

The range of the **Layher Keder Roof XL** extends, taking into account local weather conditions, to a span of up to 30 m. For low roof widths, assembly can be completely manual. In combination with gable and wall tarpaulins, completely closed enclosures can be made – the optimum solution for wintertime construction sites. The applications vary widely:

- ▶ Roofs over work on additional storeys, repairs to timber roof frames and coverings.
- ▶ Weather protection during new building work.
- ▶ Repair sites on motorways and above bridges.

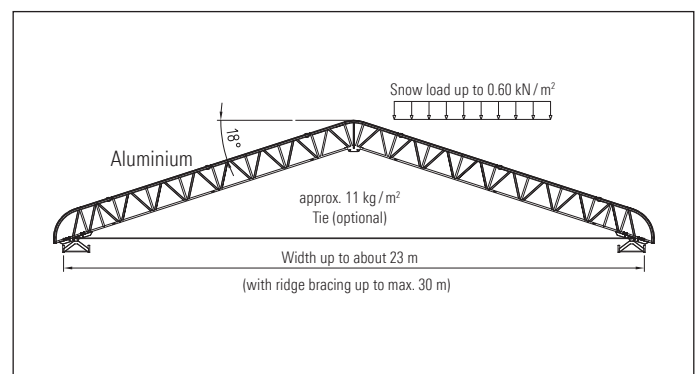



Mobile Keder Roof XL during roof work at a shopping centre



Mobile Keder Roof XL on SpeedyScaf during roof work on an office building

**The Keder Roof XL can be made mobile using a small number of additional components.** That makes this roof system even more economical, when for example only single building phases have to be roofed. Further advantages are:

- ▶ Ease during assembly without a crane, since the roof is assembled bay by bay from gable scaffolding and can be pushed forward.
- ▶ Openings for supply by crane can be created simply by pushing the roof sections apart.
- ▶ The bay width of the roof can be selected regardless of the bay width of the support scaffolding.

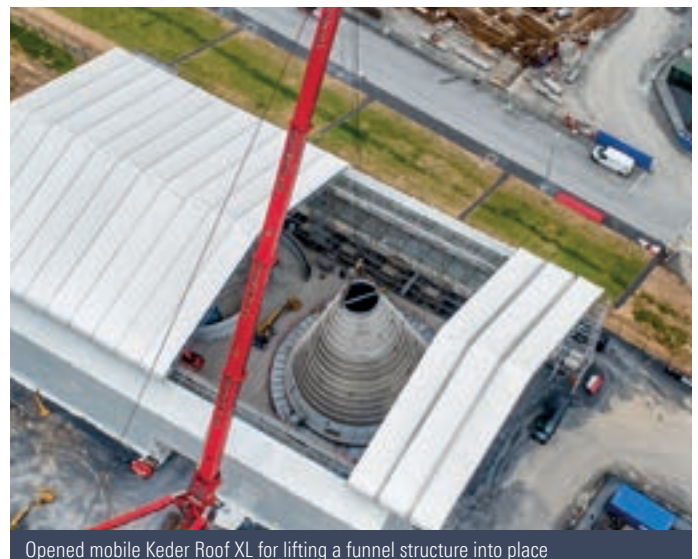

Opened mobile Keder Roof XL for lifting a funnel structure into place

## 5. Products and solutions

### 5.5. SITE EQUIPMENT

#### 5.5.1. Cable and pipeline bridges

Construction work involves numerous tasks that can be completed very quickly using Allround Scaffolding. More and more frequently, these include building cable or pipeline bridges across traffic routes. Various solutions are available depending on requirements.

- ▶ Small non-system triangular supports.
- ▶ Allround Scaffolding lattice beam structures.
- ▶ Very strong pipeline bridges made of steel trusses / Allround FW System or Allround Bridging System for large spans and high load-bearing capacities.



Cable bridge made of lattice beams and triangular supports including concrete ballast



Cable and pipeline bridges made using the Allround Bridging System



Pipeline bridge using steel trusses



Pipeline bridge using Allround support scaffolding and steel lattice beams

### 5.5.2. Advertising signs

Ingenuous system solutions using Layher Allround Scaffolding enhance the appearance of the site or storage area.

For advertising signs, structures can be quickly assembled to match various requirements using Layher's Allround Scaffolding.

- ▶ Quick to assemble and economical in the long term.
- ▶ Problem-free adjustment to the terrain.
- ▶ The structure can be stabilised using ballast or anchored directly in the foundation.
- ▶ Both temporary and permanent structures can be built.



## 5. Products and solutions

### 5.6. ACCESSORIES AND LOGISTICS

#### 5.6.1. Flat roof guardrail

The rules of the professional association (BGV) regarding health and safety when working (C22 "Construction work") require a fall protection system at workplaces and walkways on roofs where the fall height is more than 2 m.

- ▶ The GS-tested flat roof guardrail meets this requirement.
- ▶ With a few additional components for the Allround system, the flat roof side protection can be assembled easily, quickly and safely.
- ▶ This and many other products from Layher Bautechnik GmbH can be found at [www.layher-bautechnik.de](http://www.layher-bautechnik.de)



Flat roof side protection on a hall roof

#### 5.6.2. Balustrade clamp

The accident prevention regulations of the professional associations are also met with the Layher balustrade clamp. It can be used for concrete floors and fascias between 16 and 33 cm in height and for flat roofs.

- ▶ The guardrail is constructed with Allround Scaffolding or SpeedyScaf guardrails.

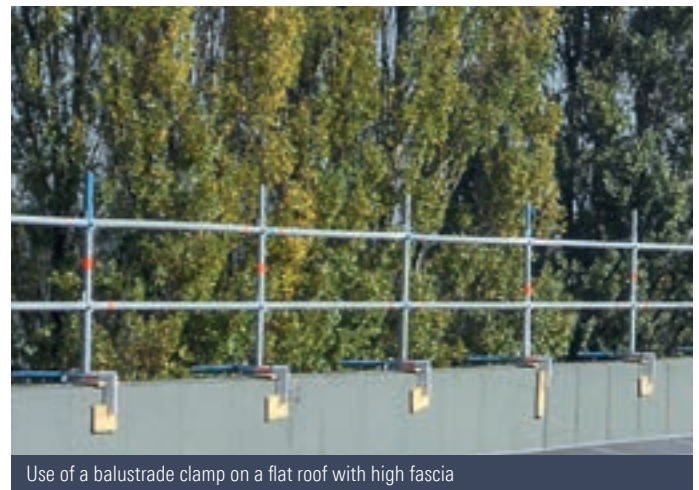

Use of a balustrade clamp on a flat roof with high fascia

#### 5.6.3. Logistics/material flow/storage

Sound logistics are essential for successful work at the site, which is why Layher has also put some thought into storage and safe transportation. For some system components, special system pallets are available.

For all other components, an extensive range of non-system pallets and skeleton boxes is available:

- ▶ System pallets.
- ▶ Sturdy design made from steel for safer transport and long life.
- ▶ Corrosion prevention by hot-dip galvanisation.
- ▶ For rapid transport of material to the right place.
- ▶ Space-saving storage.
- ▶ Movement by crane or fork-lift truck.



Modular skeleton boxes in Euro Pallet dimensions





Filled pallets are lifted from the truck directly by a crane at the place of use.



Filled TG 60 frame pallets can simply be moved on the construction site by a pallet truck.



Filled and stacked TG 60 frame pallets for transport using a fork-lift truck



Layher logistic solutions for safe transport and storage of scaffolding material

# 6. SAFETY AND DOCUMENTATION

## 6.1. LAYHER QUALITY MANAGEMENT

Layher processes some 30,000 kilometres of steel tube every year – and we take responsibility for the safety of our customers with every single metre. This is why one of Layher’s core tasks is quality management.

- ▶ Our products possess DIN/ISO certifications, German TÜV approvals plus many other German and international seals attesting their excellent quality.
- ▶ We have been DIN EN ISO 9001-certified since 1994.
- ▶ Uncompromising commitment to quality, from incoming-goods inspection to every production area.
- ▶ The manufacturing methods are precisely defined for every component and backed up by clear instructions for work and inspection.

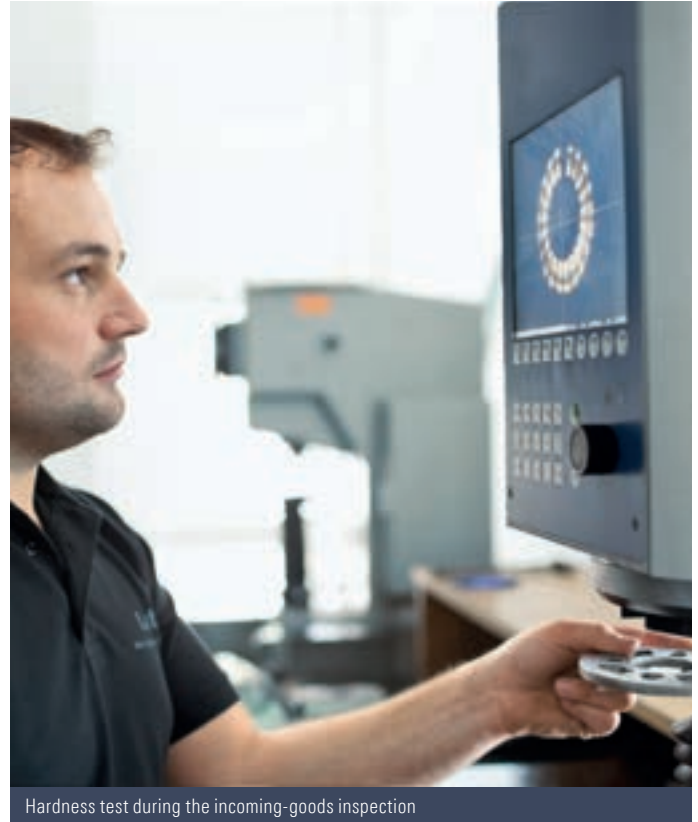

Hardness test during the incoming-goods inspection



Dimensional and function test of the semi-finished parts



Product identification to permit tracking of its manufacture

At Layher, rigorous checks at every stage of production are equally important and routine as the identification and documentation of all components. For example, every Layher deck is stamped at the end of the production process with information on the machine, the date of manufacture and various production parameters.

## 6.2. INTERNAL AND EXTERNAL MONITORING

To comply with the quality requirements and the legal basis for high-grade Layher products, they are routinely monitored with both in-house and external inspection measures.

### Internal monitoring

- ▶ 100-percent inspections of dimensional accuracy.
- ▶ Destructive random checks in all production areas.

### External monitoring

- ▶ Commissioning of independent test institutes with certification.























Monitoring by external test institutes



Laser-assisted dimensional testing

## 6.3. APPROVALS

Layher scaffolding systems have national approvals in a variety of countries – for maximum safety at work and safety under the law.

 <p>Approval for the Allround modular system in steel: Z-8.22-64, Z-8.22-939, Z-8.22-949</p> <p>Approval for the Allround Connector in aluminium: Z-8.22-64.1</p> 	 <p>Certificate for the Allround modular system in steel</p> 	 <p>Certificate for the Allround modular system in steel</p> 	 <p>Certificate for the Allround modular system in steel</p> 	 <p>Certificate for the Allround modular system in steel</p> 	 <p>Approval for the Allround modular system in steel and aluminium</p>
 <p>Approval for the Allround modular system in steel</p> 	 <p>Certificate for the Allround modular system in steel and aluminium</p> 	 <p>Certificate for the Allround modular system in steel and aluminium</p> 	 <p>Certificate for the Allround modular system in steel and aluminium</p> 	 <p>Certificate for the Allround modular system in steel</p> 	<p>Further approvals and certificates world-wide.</p> <p>In a number of countries, the listed approvals or certificates are also accepted.</p>

## 6. Safety and documentation

### 6.4. WELDING TECHNOLOGY

Layher is a certified company for welding technology. We process our products on the latest welding equipment and with welding robots.

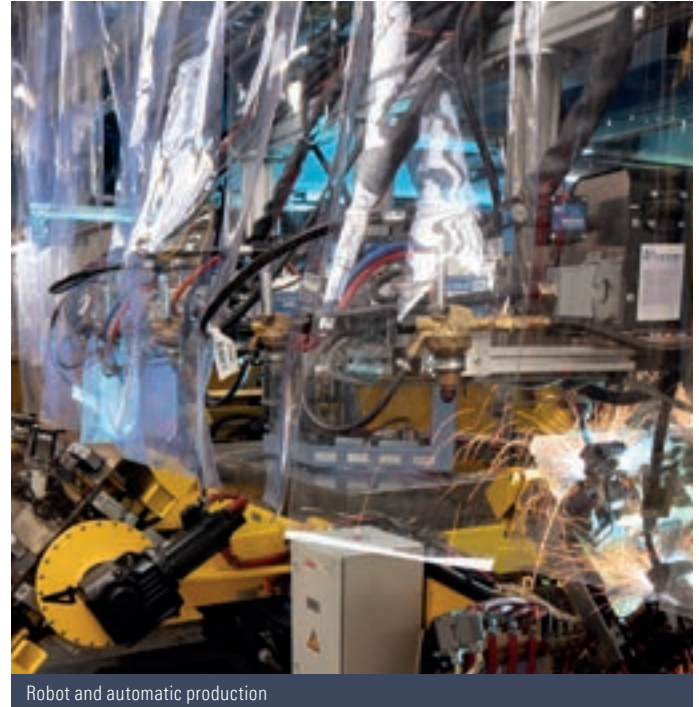
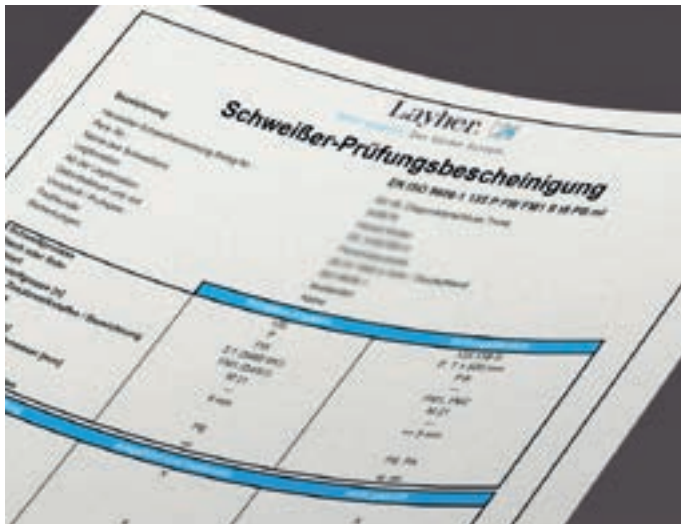

Robot and automatic production

### 6.5. TRIAL AND TEST STAND

Before they come onto the market, all products are thoroughly tested on Layher's up-to-date test stand. This can involve the simulation of thousands of load cycles, and drop tests are conducted too. These drop tests have to be passed by all scaffolding decks before they can be used in brick guards.

The ball drop test conducted in accordance with EN 12810-2 is strictly regulated. It is conducted with a steel ball with a weight of 100 kg and a diameter of 0.5 metres, impacting the scaffolding deck from a drop height of 2.5 metres. To simulate the impact of a human body, a cushioning pad with precisely defined properties is positioned at the point of impact. The deck may be deformed, but must not fail.

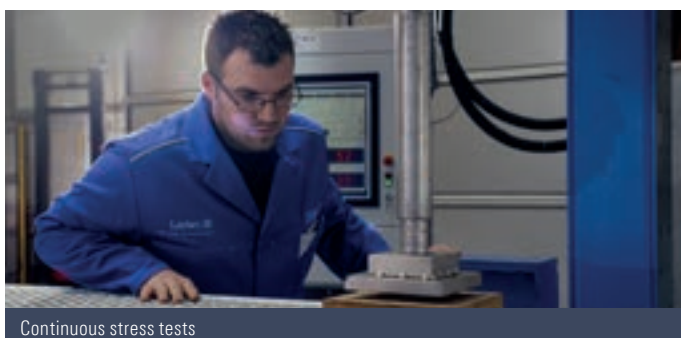

Continuous stress tests



Ball drop test

## 6.6. TECHNICAL DOCUMENTATION

For planning certainty, extensive technical documentation is available for Layher scaffolding systems:

- ▶ Approvals.
- ▶ Type tests for lattice beams.
- ▶ Instructions for assembly and use.
- ▶ Structural data sheets.
- ▶ Comprehensive technical brochures with load capacity tables.



Detailed technical documentation

## 6.7 CATALOGUES AND PRICE LISTS

Layher customers can find extensive information material for downloading at [downloads.layher.com](https://downloads.layher.com) or they can request it in printed form free of charge.

- ▶ Layher Product Range.
- ▶ Layher Guideline for Professional Users.
- ▶ Layher Infos with useful information for the scaffolding user, plus information on new products and on their possible uses and applications.



Price lists for dependable costing of projects

# 7. SUSTAINABILITY

LAYHER IS THE NATURAL CHOICE. QUITE LITERALLY.



Sustainability is an integral part of the Layher business philosophy. We engineer our processes for the efficient use of materials and the conservation of resources. And we design our buildings to be eco-friendly, with green roofs and photovoltaic panels. What's more, by consolidating all manufacturing of Layher products at our Gueglingen sites, there is no need for goods transport, greatly reducing our carbon footprint.

In fact, sustainability is embedded throughout the entire Layher organisation, and backed by a dedicated energy management team. The basis for all related activities is DIN EN ISO 50001. This standard defines requirements in terms of energy management and consumption. It applies to the following key areas:

▶ PRODUCTS ▶ INITIATIVES ▶ PROCESSES



## 7.1. PRODUCT SUSTAINABILITY

### Integrated System

- ▶ New components can be combined and used with existing inventory.
- ▶ Durable products that have a long service life.
- ▶ Certification applies to multiple system generations.

### Layher Lightweight

- ▶ The use of high-tensile steel has enabled us to cut the weight of scaffolding components to be transported by up to 15%.
- ▶ This means each truck can carry more parts, leading to fewer trips and lower carbon emissions.

### Solution-driven products

- ▶ Reusable Layher Protective Systems for enclosures and protection of construction sites.
- ▶ No need for use and subsequent disposal of tarpaulin.



## 7.2. SUSTAINABILITY THROUGH INITIATIVES

### Lower energy consumption

- ▶ Targeted building modernisation, including regular roof improvements, and the replacement of roller doors with faster, more innovative versions to minimise heat loss.
- ▶ Replacement of conventional lighting with LED systems and regular IT system upgrades to save electricity.

### Vehicle fleet

- ▶ Diesel forklift trucks are to be replaced by electric vehicles.

### Renewables and energy efficiency

- ▶ Photovoltaic panels and green roofs are standard for new buildings.

### Recycling

- ▶ Waste wood generated in the manufacture of toe boards are used as fuel for the drying chamber deployed in the same production process.

### Paperless/paper-saving offices and carbon-neutral production of all print media, such as brochures and price lists.



## 7.3. PROCESS SUSTAINABILITY

### 10-year goal for energy efficiency

- ▶ 10% less energy consumption per manufactured unit.

### Production sites and systems

- ▶ Short distances between sites and targeted allocation of production tasks for a smaller CO<sub>2</sub> footprint.

### Suppliers

- ▶ Raw materials are selected and sourced in line with ecological and sustainability criteria. Layher only partners with suppliers who also have corresponding ISO certification.
- ▶ All equipment purchased fulfils the highest energy efficiency class.

### Production

- ▶ New production technologies and efficient processes ensure the conservation of resources and high product quality.
- ▶ The energy efficiency class KfW 55 applies to all new buildings.
- ▶ Innovative heating systems, a combined heat-and-power (CHP) plant, and an air compressor with heat recovery ensure the efficient management of interior temperatures.

Economic and ecological sustainability is central to the Layher business model. And there is a focus on our responsibilities towards employees, customers and society as a whole.



New multi-storey car park in Heilbronn, Germany



New office building in Bamberg, Germany



New office building in Berlin, Germany



New residential and office buildings in Heilbronn, Germany



IDEAS. SOLUTIONS. POSSIBILITIES.

# Success stories



The following success stories, and many others too, can be found in various issues of our "Success stories" magazine.

Request it free of charge at: [brochurerequest.layher.com](http://brochurerequest.layher.com)



All success stories can be watched as videos at [www.scaffoldingstories.com](http://www.scaffoldingstories.com)



## 8. Success stories

### 8.1. NEW MULTI-STOREY CAR PARK, HEILBRONN, GERMANY

As Managing Director Horst Köhler walks through his new company headquarters in Besigheim, Germany, a certain building material is omnipresent at every step. The winner of an architecture competition, this new building was envisaged as a kind of calling card for the company as a whole. This involved the creative use of concrete, one of the pet projects of the company. The newly built multi-storey car park for the company Heilbronner Versorgungs GmbH also employed concrete, albeit much less creatively. To provide both economical and dependable formwork for the car park decks, Köhler unerringly chose Shoring TG 60 from Layher.

The TG 60 system replaces frames, standards, ledgers and diagonal braces, meaning that fewer individual parts have to be assembled. As a result, assembly and dismantling are particularly fast. And can always be carried out from a secure position thanks to the integrated and all-round side protection. The towers can be assembled both upright and lying on their sides. To support the base plates on the sloped access, adjustable equalising plates are used which can compensate steplessly for inclines of up to 16% and thus ensure sure footing. A work level integrated into the system underneath the car park deck enables the concrete workers to work quickly, more safely and untiringly. Allround Scaffolding can display its advantages to the full during work on the access ramps. With a loading capacity of up to six tonnes per standard.

Learn more at: [www.scaffoldingstories.com/Koehler](http://www.scaffoldingstories.com/Koehler)



## 8.2. NEW OFFICE BUILDING, BERLIN, GERMANY

If you walk with Dieter Gescher (structural design expert at Teupe & Söhne Gerüstbau GmbH, Technical Director of Teupe GmbH Stahl- und Maschinenbau and head of the Technical Office with 14 employees) through the new and breathtaking Axel Springer building, you will soon find his delight in the technical details of this construction project infectious.

Ever since the order was placed with the Teupe Group by Züblin, the main contractor responsible for the building, in November 2016, it has had a small army of structural engineers and technicians working on this major and ambitious project. The entire structural analysis for the scaffolding needed, the engineering work and job preparation was done by the company itself. The modular Layher Allround system considerably facilitated planning of the scaffolding. Starting in March 2017, the scaffolding construction specialists from Teupe have been represented continuously by up to 20 employees working not only on the large birdcage scaffolding and shoring, but also on facade and protective scaffolding, stairtowers and various one-off structures for the project. For the birdcage scaffolding, up to 40 m tall Layher Allround Scaffolding was used for shoring to absorb loads from 12 kN/m<sup>2</sup> to 40 kN/m<sup>2</sup>, in addition to Teupe's heavy-duty towers. "Shifting the load to the deck structure and a step-by-step dismantling of the birdcage scaffolding was scheduled for the period from October 2018 to April 2019, which will be another highlight at this site for us", says Dieter Gescher. "Apart from the structural aspects, the logistics of this inner-city project were another challenge that couldn't be underestimated, since the entire material used couldn't be put into interim storage at the site, and more than 100 truckloads of material had to be delivered just in time instead. Something like that can only work with perfected planning for both the scaffolding and its assembly", adds Ludger Schroer.

Learn more at: [www.scaffoldingstories.com/Teupe](http://www.scaffoldingstories.com/Teupe)



## 8. Success stories

### 8.3 NEW RESIDENTIAL AND OFFICE BUILDINGS, HEILBRONN, GERMANY

A fantastic challenge for the senior site engineer Horst Zimmermann and all his team. Placing this major project with AMOS was no coincidence: it's a construction company with a long tradition and 80 years of experience in civil engineering and road construction, and it also handles the entire value chain, from project planning to completion. "With our well-trained employees and an extensive fleet of our own machinery and equipment, we are extremely flexible and well prepared to take on out-of-the-ordinary jobs too", emphasises Klaus Wenninger. And that's in the truest sense of the word, because there is enough Layher Allround Scaffolding material on his premises that he no longer has to hire any additional scaffolding for projects. "That gives us enormous flexibility and saves a lot of time too", adds Horst Zimmermann.



Senior site engineer Zimmermann appreciates not only the economic benefits of this system, but also – and above all – its quality and its compatibility, in particular for buildings that have to meet exacting standards. "We use our Layher Allround material in the building process above all to provide flexible and safer access to work areas that are not easily reached." Horst Zimmermann is well aware of the heavy responsibility for his employees, which is precisely why he relies on Layher material. "The uncomplicated assembly of the scaffolding elements saves time and can also be used for unusual building geometries." When it comes to fitting the Layher stop-end brackets at a section of the construction, AMOS uses its Allround material to build a free-standing tower about four metres in height, for example, which can be transported in a very uncomplicated way to the right place by crane. "That allows our employees to work with a secure feeling even at great heights, and concentrate fully on the quality of their work – tiresome assembly and dismantling is not needed."



Find out more at: [www.scaffoldingstories.com/Amos](http://www.scaffoldingstories.com/Amos)



## 8.4 VARIOUS PROJECTS, BAMBERG, GERMANY

When you stand on Bamberg's "upper bridge" and look across the Regnitz to the old town hall, you will feel pretty close to the Middle Ages. The historic Old Town is one of the biggest and largely intact mediaeval town centres in Germany, and was even placed on the UNESCO's World Heritage List in 1993. Directly behind the Regnitz is Cathedral Hill, where today's cathedral and Bamberg's most famous symbol, the Bamberg Horseman statue, were erected in the first half of the 13th century. Whenever building work is done here, the Karl company, offering scaffolding construction/hire and formwork construction, is never far away. With its focus on historic preservation, special scaffolding construction and one-off structures, this family company is excellently placed in the region and well equipped for every job thanks to Layher scaffolding systems.



The company was one of the first to use the Allround STAR Frame, Allround Shoring TG 60, the Allround Bridging System and the innovative advancing Allround Guardrail System (ARGS) in actual practice. "We're driven by the ambition to keep on improving so that we can sustain our success. The innovative solutions and expansion parts from Layher help us to do so. That's why we're always interested in new things and why we test all the ideas from Eibensbach at our construction sites. And I have to say that we're surprised every time by how the existing products can always be made a little bit better", says Kevin Fleischmann, scaffolding construction expert and site engineer of the company.



Find out more at: [www.scaffoldingstories.com/Karl](http://www.scaffoldingstories.com/Karl)



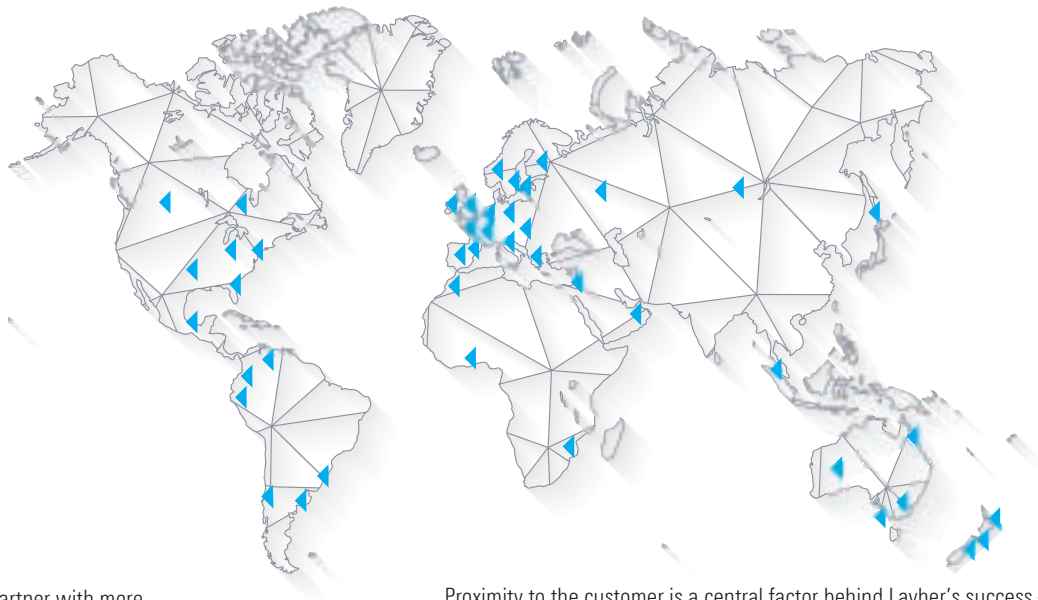

Layher is your dependable partner with more than 75 years of experience. "Made by Layher" always means "Made in Germany" too – and that goes for the entire product range. Superb quality – and all from one source.

Proximity to the customer is a central factor behind Layher's success – geographically speaking too. Wherever our customers need us, we will be there – with our advice, assistance and solutions.

	<b>SpeedyScaf</b>
	<b>Allround Scaffolding</b>
	<b>System-free Accessories</b>
	<b>Protective Systems</b>
	<b>Shoring</b>
	<b>Event Systems</b>
	<b>Rolling Towers</b>
	<b>Ladders</b>
	<b>Software</b>



Headquarters in Eibensbach



Plant 2 in Gueglingen

**Layher** 

More Possibilities. The Scaffolding System.

**Wilhelm Layher GmbH & Co KG**  
Scaffolding Grandstands Ladders

Ochsenbacher Strasse 56  
74363 Gueglingen-Eibensbach  
Germany

Post Box 40  
74361 Gueglingen-Eibensbach  
Germany

Telephone +49 (0) 71 35 70-0  
Telefax +49 (0) 71 35 70-2 65  
E-mail [export@layher.com](mailto:export@layher.com)  
[www.layher.com](http://www.layher.com)

